

## har-modular female str. pre-ass L40,64

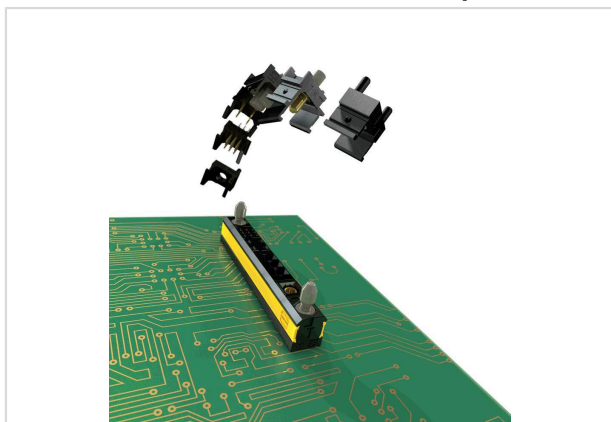

Image is for illustration purposes only. Please refer to product description.

Part number	C0 25 200 0000 0012
Specification	har-modular female str. pre-ass L40,64
HARTING eCatalogue	<a href="https://b2b.harting.com/C02520000000012">https://b2b.harting.com/C02520000000012</a>

### Identification

Category	Connectors
Series	har-modular®
Element	Female connector
Specification	Pre-assembled connector
Description of the contact	Straight

### Version

Installed modules	1x 02529031301	<a href="https://b2b.harting.com/02529031301">https://b2b.harting.com/02529031301</a>
	1x 02529091101	<a href="https://b2b.harting.com/02529091101">https://b2b.harting.com/02529091101</a>
	2x 02529000002	<a href="https://b2b.harting.com/02529000002">https://b2b.harting.com/02529000002</a>
Length	40.54 mm	
Termination method	Reflow soldering termination (THR)	
	Wave soldering termination	
Connection type	Motherboard to daughtercard	
	Mezzanine	

### Technical characteristics

Insulation resistance	$>10^{11} \Omega$
Limiting temperature	-55 ... +125 °C (during reflow soldering max. +240 °C for 15 s)
Performance level	1
	acc. to IEC 60603-2
Mating cycles	$\geq 500$
Isolation group	I ( $600 \leq CTI$ )
Hot plugging	No



Pushing Performance  
Since 1945

## Technical characteristics

Moisture Sensitivity Level (MSL)	1 acc. to ECA/IPC/JEDEC J-STD-020D
----------------------------------	------------------------------------

## Material properties

Material	Polyamide (PA)
Material flammability class acc. to UL 94	V-0
RoHS	compliant
ELV status	compliant
China RoHS	e
REACH Annex XVII substances	Not contained
REACH ANNEX XIV substances	Not contained
REACH SVHC substances	Not contained
California Proposition 65 substances	Not contained
Requirement set with Hazard Levels	R26

## Specifications and approvals

UL / CSA	UL 1977 ECBT2.E102079 CSA-C22.2 No. 182.3 ECBT8.E102079
Railway classification	F1/I2 acc. to NFF 16-101/102

## Commercial data

Packaging size	12
Country of origin	Romania
European customs tariff number	85366990
GTIN	5713140476486
eCl@ss	27460201 PCB connector (board connector)

### Mating conditions

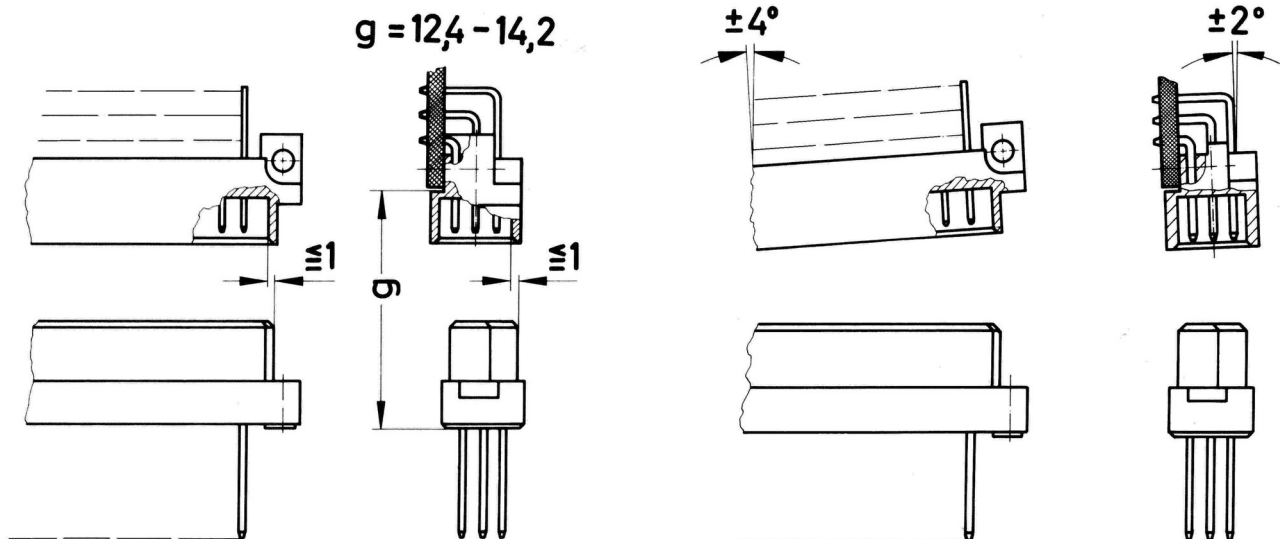

To ensure reliable connections and prevent unnecessary damage, please refer to the application data diagrams. These recommendations are set out in IEC 60603-2. The connectors should not be coupled and decoupled under electrical load.