

CORNING

Fibrlok® II Splice/Holder 2539

P/N 78-8135-6778-7

Issue 2

related literature | [Search corning.com/opcomm](https://www.corning.com/opcomm). Click on "Resources/Standard Recommended Procedures."

INSTRUCTIONS

CONTENTS:

1.0 General 3

2.0 Safety and Helpful Hints..... 4

3.0 Tools and Materials Required 4

4.0 Splicing Setup 4

5.0 Fiber Preparation 5

6.0 Splice Assembly 6

7.0 Securing the Corning® Fibrlok® Splice/Holder 2539..... 7

8.0 Fiber Repositioning 8

1.0 GENERAL

1.1 The Corning® Fibrlok® II Splice/Holder 2539 enables fast, on-site installation of fiber to the premise (FTTP) connections without an installation tool. The Corning Fibrlok II Universal Optical Fiber Splice provides permanent mechanical splices for use with either singlemode or multimode fibers with a (nominal) glass cladding diameter of 125µm. It is designed to accommodate any combination of fibers with coating diameters from 250µm to 900µm.

1.2 All 2529 universal optical fiber splices are gray in color and are marked with Fibrlok II logo on the splice cap.

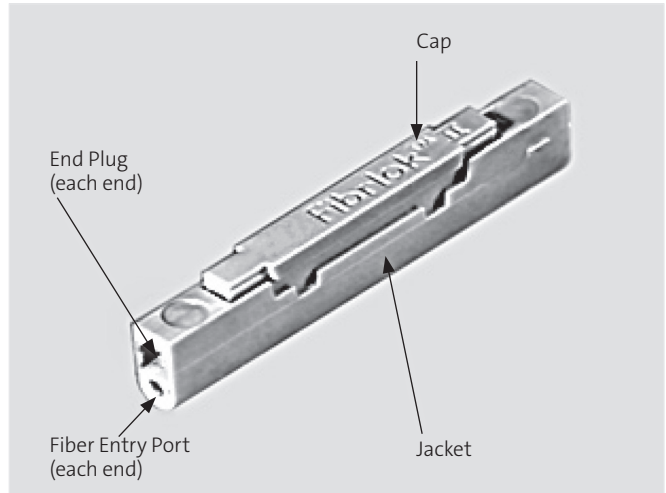
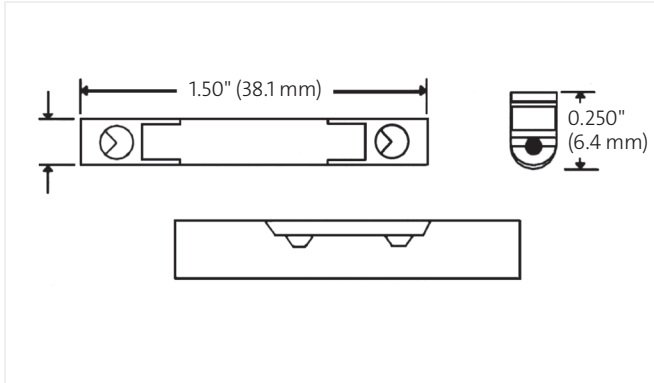

1.3 Fibrlok II Splice/Holder 2539

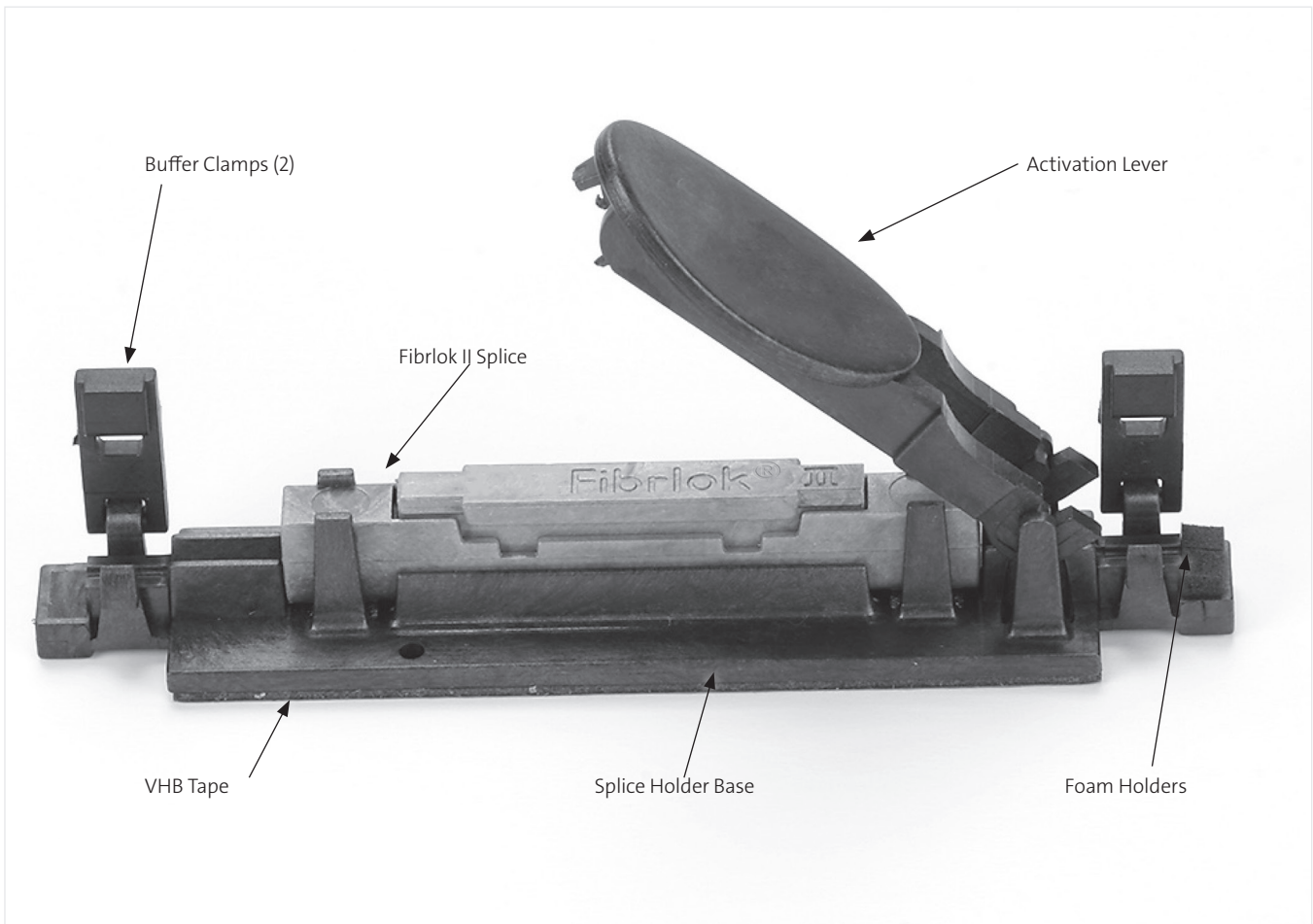

2.0 SAFETY AND HELPFUL HINTS

2.1 Use reagent-grade isopropyl alcohol that is 99% pure to clean the fibers and other components. When splicing any cable containing grease, ensure that all grease is wiped away and the buffer coating and fiber are thoroughly cleaned with isopropyl alcohol.

Note: Carefully follow safety, health, and environmental information given on product label or the Safety Data Sheet (SDS).

CAUTION

May cause minimal eye irritation.

Contains: Phenylmethyl silicone (63148-58-3), hydrophobic silica (68611-4444-9).

Precautions: Avoid eye contact. Wash hands before eating or smoking.

First Aid:

Eye Contact: Immediately flush eyes with plenty of water while holding eyelids open and continue flushing for ten minutes. Call a physician.

Skin Contact: Wash with soap and water.

2.2 Carefully follow safety, health, and environmental information given on product label or the Safety Data Sheet (SDS).

CAUTION

Safety glasses should be worn while working around optical fibers.
Do not view fiber ends if they are illuminated with a laser.

3.0 TOOLS AND MATERIALS REQUIRED

- Corning Fibrlok II Splice/Holder 2539
- Buffer Stripper
- Reagent Grade Isopropyl Alcohol
- Lint-free Wipes
- Cleaver

4.0 SPLICING SET-UP

4.1 The splicing area should be clean, dry and well lit. A clean, well organized splicing area will improve splice efficiency and minimize the risk of contamination of fibers or splices.

4.2 Open buffer tubes, expose and clean the fibers per your company practice.

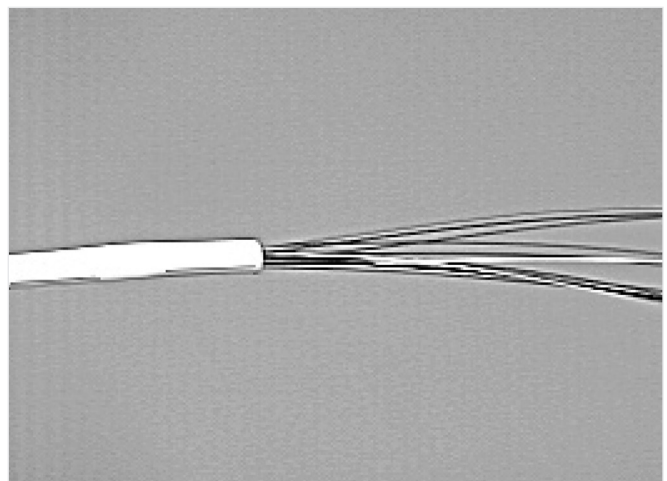

4.3 Remove Corning® Fibrlok® II Splice/Holder from protective package.

4.4 Buffer clamps at both ends of the splice/holder should be unlatched and positioned up.

4.5 Actuation button on the splice/holder should be lifted to the up position.

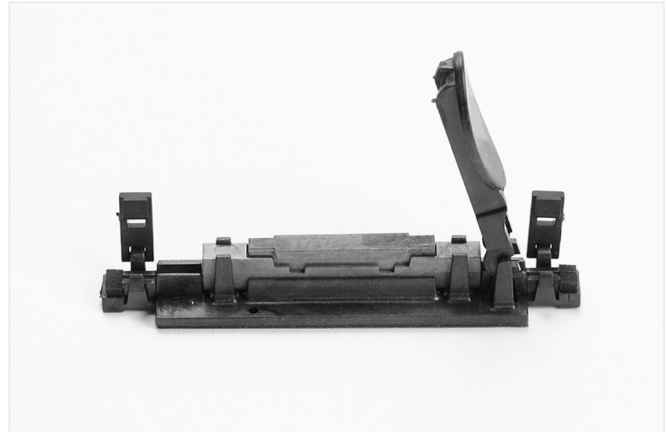

5.0 FIBER PREPARATION

5.1 Remove the minimum length of fiber required to prepare and splice the fibers.

5.2 Strip approximately 1 to 2 inches (25mm to 51mm) of plastic coating from the fiber using a mechanical stripper.

Note: *The stripper should be in good operating condition to prevent scratches or other damage to the glass cladding.*

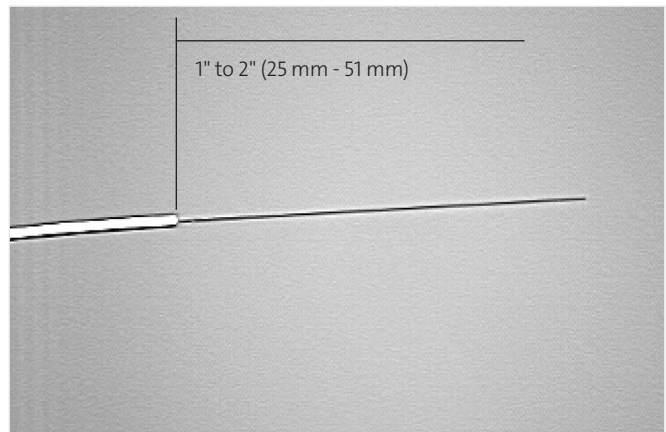

5.3 Clean the bare glass by pulling the fiber through an alcohol soaked lint-free wipe. This will remove any fragments or dirt remaining on the fiber.

Note: *Do not wipe the fibers more than two times, and limit the time that the bare fiber is exposed to the atmosphere.*

5.4 Cleave the fiber to 0.492 ± 0.020 inches (12.5mm \pm 0.5mm).

Note: *The Fibrlok II Universal Splice 2529 uses a cleave length of 0.492 ± 0.020 inches (12.5mm \pm 0.5mm) for both 250um and 900um coated fibers.*

Note: The cleaver should be in good operating condition and used in accordance with the manufacturer's instructions. It is recommended that the cleaver provide a consistent cleave-to-coating length with $\pm 0.5\text{mm}$. In addition, standard cleavers should produce cleaved ends within 2° of perpendicular and free of major defects. Cleavers specifically designed to produce controlled, angled cleaves of greater than 2° , but not more than 6° , may also be used with the Corning® Fibrlok® II Optical Splice.

Note: Do not allow cleaved end to contact tool. Do not clean the fibers again after they have been cleaved.

6.0 SPLICE ASSEMBLY

6.1 Holding the fiber approximately .25 inches (6mm) from the bare glass, insert fiber into the guide on the left side (opposite the actuation lever attach point) of the splice/holder.

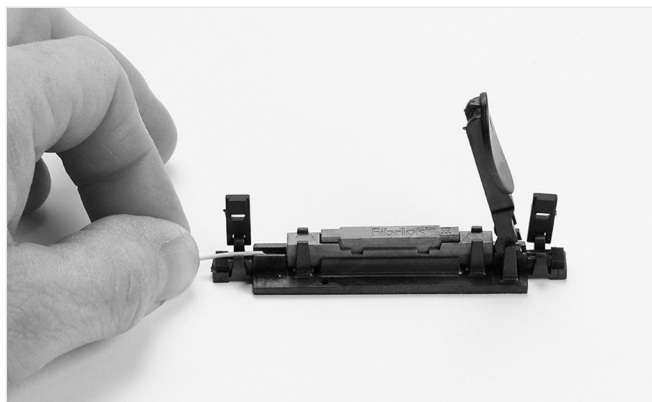

6.2 Slide the first fiber into the splice until it stops or bottoms out.

Note: Push fiber straight into the fiber alignment guide, not at an angle.

Note: If properly inserted, bare glass should not be visible outside of the splice. If bare glass is visible, pull back slightly on the fiber and continue insertion until resistance is met. Never fully remove fibers from splice after initial insertion. Do not pull on fiber after it has been properly inserted.

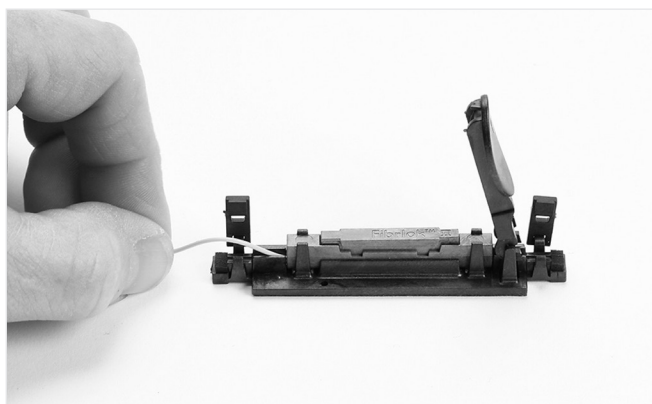

6.3 Prepare second fiber (strip, clean and cleave) as described in section 5.

6.4 Holding the fiber approximately .25 inches (6mm) from the bare glass, insert second fiber in the guide on the right side (actuation lever attach point side) of the splice/holder.

6.5 Slide the second fiber into the splice until it stops or bottoms out. While you are sliding the second fiber into the splice, you should see the first fiber being pushed out of the splice a short distance. This ensures the fiber ends are in contact. If you don't see this happen, recheck the cleave length of both fibers.

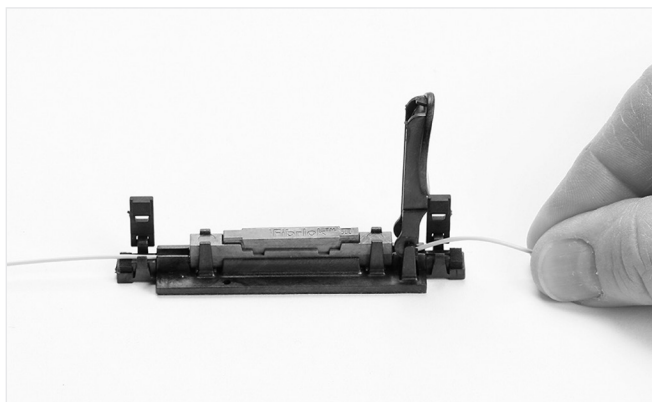

6.6 Once the second fiber is fully inserted, fully close the buffer clamp.

Note: *Be sure to pull latch on clamp completely forward to ensure proper closure. Latch should be aligned with guide on clamp.*



6.7 After checking to make sure the buffer clamp on the right is fully closed, create a small bow of at least .1 inch (3mm) in the first fiber to maintain forward pressure and hold in place. Grasp the fiber about 2 inches from the holder and push the fiber in until it bows about .12 - .2 inches (3mm-5mm). Push down on the Activation Lever of the splice/holder until the Corning® Fibrlok® II Universal Splice is activated. An audible click can be heard and you should feel the splice cap snap down into place when completely closed. The cap should be level with the rest of Fibrlok splice top surface.

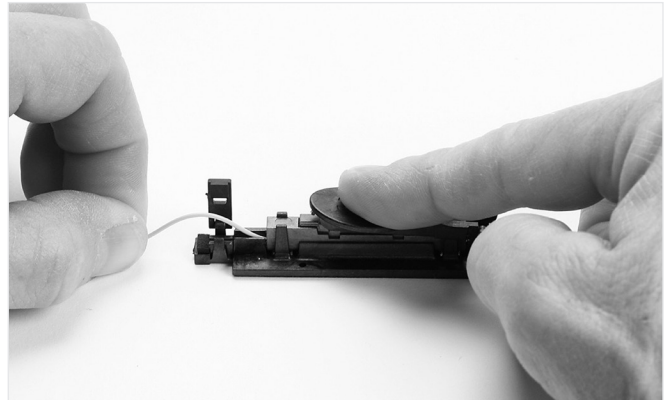

6.8 Release the bow in the fiber on the left.

6.9 Close the buffer clamp on the left. Make sure that the latch is pulled completely forward when clamped.

Note: *Be sure to push latch on clamp completely forward to ensure proper closure. Latch should be aligned with guide on clamp.*

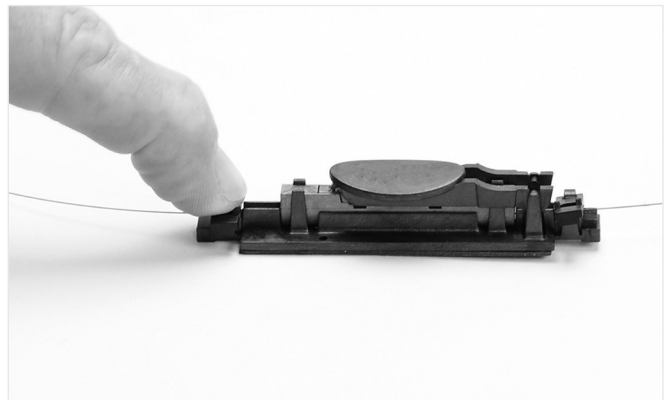

7.0 SECURING THE FIBRLOK II SPLICE/HOLDER 2539

7.1 After completing the splice, the splice/holder can be secured in its final location. Clean surface of dirt and debris with alcohol and a lint-free cloth. Remove the tape release liner and press tool onto the surface of its final location.

7.2 Activation lever can be removed and discarded if desired.

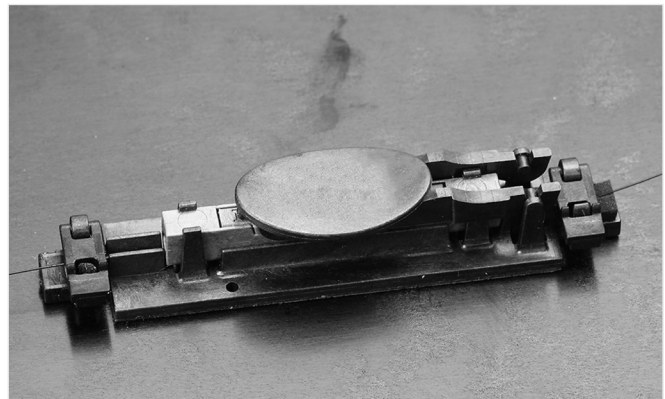

8.0 FIBER REPOSITIONING

8.1 If high loss is observed after splice has been actuated it is possible that the fiber ends are separated. In this case, lift the splice cap and reposition the fiber ends, as instructed below.

Note: *Do not completely remove fibers from the Corning® Fibrlok® Splice.*

8.2 While the splice is still in the holder assembly, lift the activation lever (if still positioned on the tool) and insert the cap removal tool over the splice cap, making sure to grasp the bottom of both sides of the splice holder and gently lift. The cap will lift up and off the splice.

8.3 Carefully reposition fiber. Refer to section 6.0 for proper fiber centering and splice actuation.

8.4 Place splice cap back on the Fibrlok splice and push down on the activation lever button until cap has been fully activated.

8.5 If after two attempts an acceptable splice loss is not obtained, remove fiber, strip, clean and re-cleave. Re-splice using a new splice.



SUMMARY

1. Remove Corning Fibrlok Splice/Holder from package.
2. Prepare Fiber.
3. Cleave Fiber to 0.492 ± 0.020 inches ($12.5\text{mm} \pm 0.5\text{mm}$).
4. Insert first fiber in the guide opposite the actuation lever attach point until it bottoms out.
5. Insert second fiber in the guide on the actuation lever attach point side of the splice/holder until you see movement from the first fiber.
6. Close clamp on second fiber.
7. Make small bow on first fiber to ensure forward pressure.
8. Grasp the fiber about 2 inches from the holder and push the fiber in until it bows about .12-.2 inches (3mm-5mm).
9. Push down activation lever until audible click is heard.
10. Release bow.
11. Close clamp on first fiber.
12. Secure splice/holder in its final location.