

# CORNING

## Centrix™ System Mounting Bracket for OCC-031 and OCC-051 Cabinets

P/N 003-988-AEN  
Issue 4

### related literature |

003-948	Instruction, Centrix™ System Housing Installation
003-949	Instruction, Centrix System Pigtailed Housing with Pigtailed Cassette Installation
003-951	Instruction, Centrix System Stubbed Housing Installation

### 1. Carton Contents

- OCC/CTX mounting bracket with hub (Figure 1)

### 2. Tools and Materials Required

- Phillips screwdriver

### 3. Installation

**Step 1:** Open the front door of the optical cross-connect (OCC) cabinet.

**Step 2:** Remove the hardware holding each factory-installed mounting bracket to the upright frame (Figure 2).

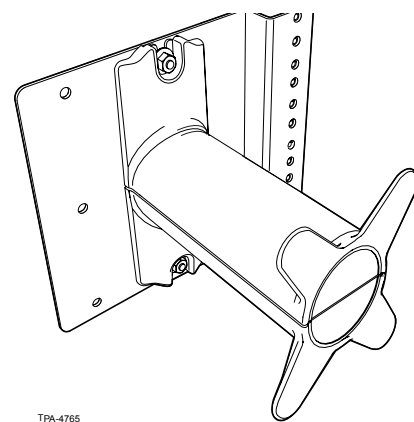

Figure 1

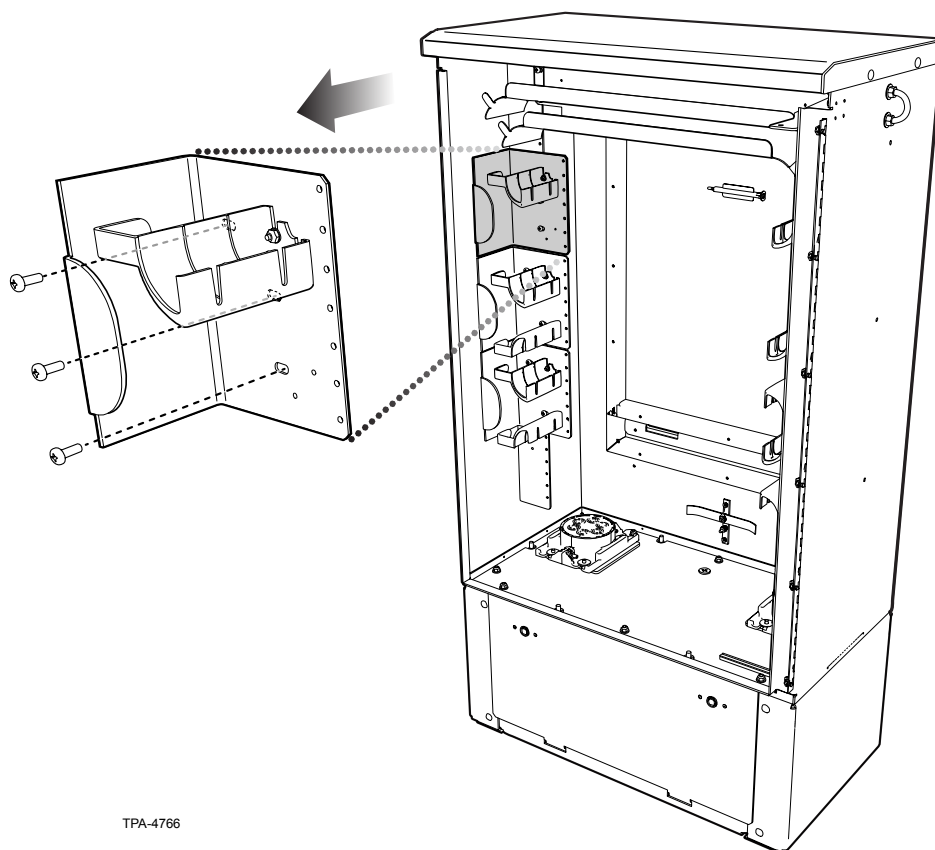

Figure 2

**Step 3:** Using the screws provided, attach the OCC/CTX mounting brackets to the upright frame.

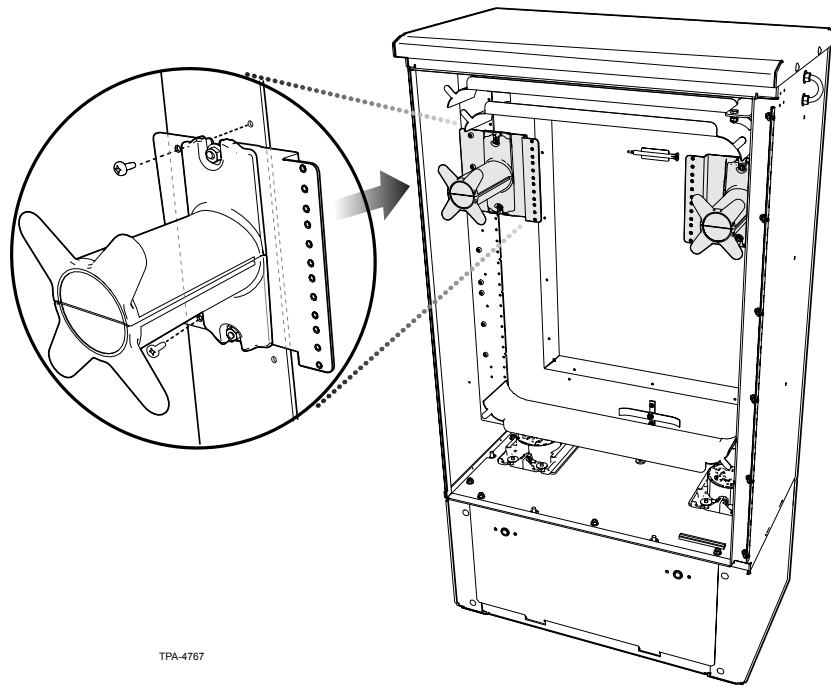

Figure 3

**Step 4:** Remove the Centrix™ System housing from its packaging.

**NOTE:** *If stubbed housing is equipped with a horizontal shipping plate supporting the cable at the rear of the housing, unscrew and discard the plate before installing the housing into the cabinet.*

**Step 5:** Reposition the cable strain-relief bracket (if necessary) to the forwardmost mounting position at the rear of the housing.

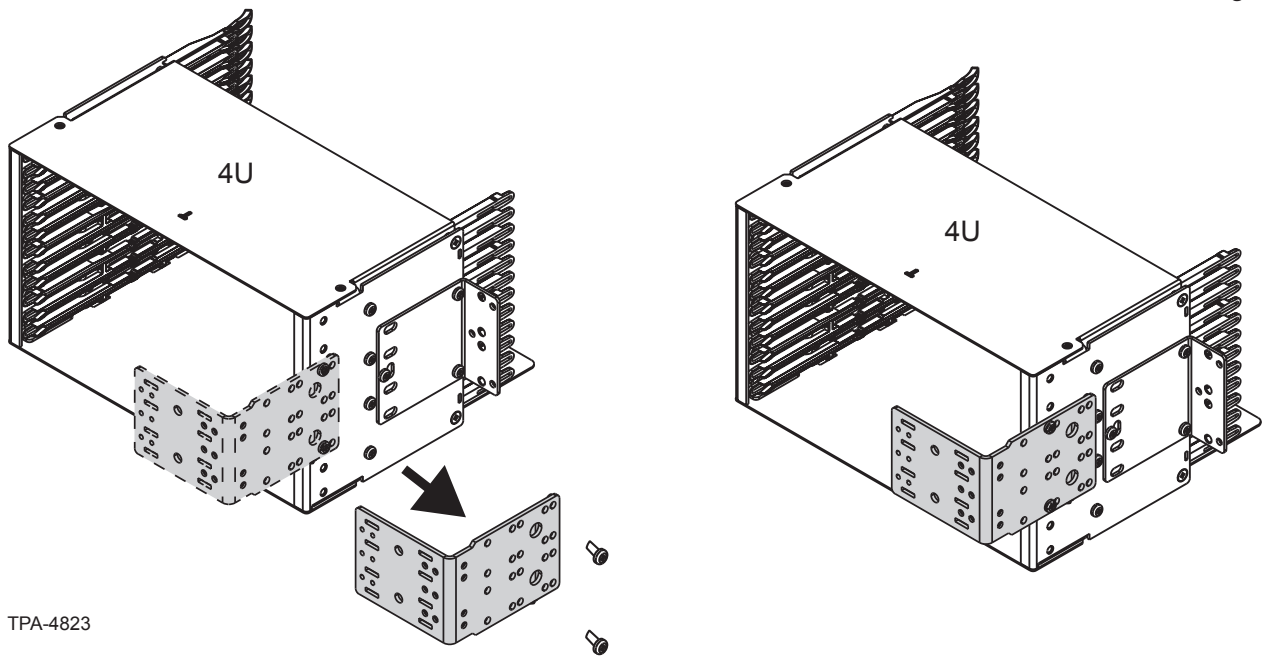
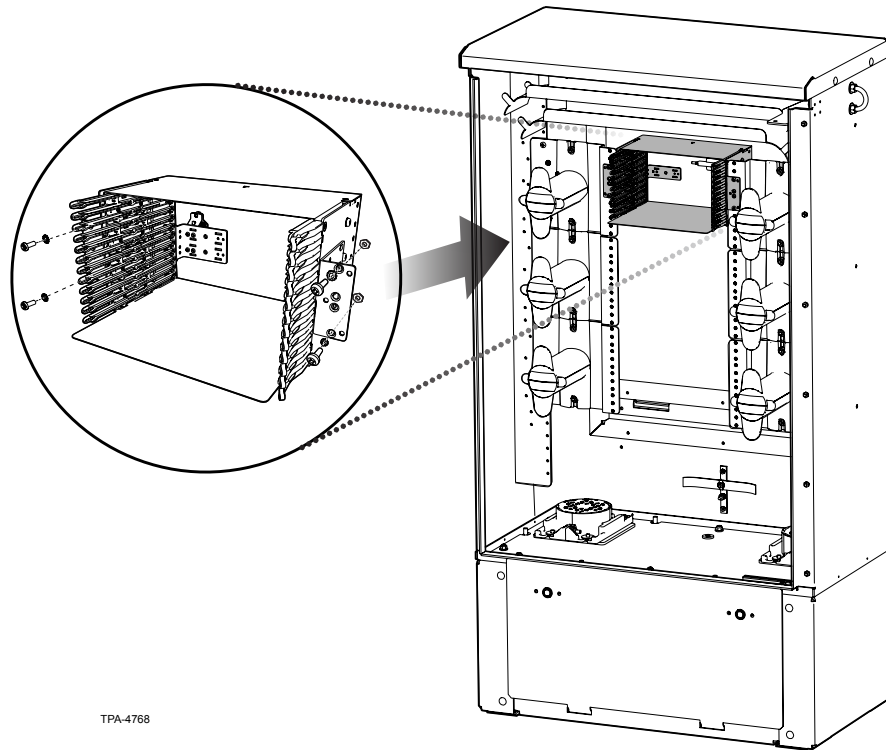

Figure 4

**Step 6:** Install the Centrix™ System housing per the instructions provided with the housing (Figure 5).



TPA-4768

Figure 5