

Wall mounting appliance inlet - with hinged cover



Product description	
BALS-Prd.-Nr	24017
EAN	4024941240178
Product category	Wall mounting appliance inlet
Current	32A
Number of poles	3p
Arrangement of phases	2P+PE
Position of earth contact	6 h
Voltage	200 - 250V~
Frequency	50/60Hz

Product description	
Protection degree	IP44
Colour code	blue RAL 5015
Colour of appliance	Hinged lid grey RAL 7035, Collar blue RAL 5015, Enclosure grey RAL 7035
Connection design	with screw terminal
Maximum conductor size	6,0 qmm
Cable entry	top entry M25
Height	147mm
Width	90mm
Depth	117mm
Dimension of enclosure	75x90 mm (HxW)
Material of enclosure	Polyamide
Contacts	the contact carrier is made of polyamide, the contacts are brass

Additional technical properties	
	The cable entry is one at top open and one rear sided closed
	With hinged lid

Logistics data	
Weight/pcs	0.31 kg / Piece
Packaging	Bag
Content amount	1 ST

Logistics data	
EAN	4024941240178
Length	117 mm
Width	90 mm
Height	147 mm
Weight	0.311 kg
Volume	1,547.91 ccm
Packaging	Carton
Content amount	10 ST
EAN	4024941832694
Length	325 mm
Width	217 mm
Height	210 mm
Weight	3.306 kg
Volume	13,588.4 ccm

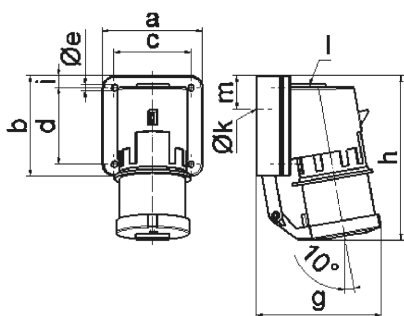

5 MB 12

Ampere Polzahl	16 5	32 3	32 4	32 5
a	84,0	90,0	90,0	90,0
b	84,0	75,0	75,0	75,0
c	64,0	78,0	78,0	78,0
d	64,0	45,0	45,0	45,0
e ø	5,5	5,5	5,5	5,5
g	105,0	114,0	114,0	115,0
h	138,0	149,0	149,0	150,0
i	10,0	13,0	13,0	13,0
k ø	23,0	29,0	29,0	29,0
l	M20	M25	M25	M25
m	28,0	27,0	27,0	27,0
Leiter mm ² min	1	2,5	2,5	2,5
Leiter mm ² max	2,5	6	6	6