



ECOOS2, ECOOS2 slim - single luminaire

- continuous row set

- emergency options:
E3D (self-contained)
ECD (centrally supplied)

- BC



ECOOS II



ECOOS II slim



EN Mounting instructions

Important notices. Please, read first! Keep the instructions safe! Specifications are subject to change without notice! If you have questions, please contact the manufacturer.

DE Montageanleitung

Wichtige Hinweise. Bitte zuerst lesen! Anleitung aufbewahren! Technische Änderungen vorbehalten! Bei Fragen wenden sie sich an den Hersteller.

FR Notice de montage

Remarques importantes. À lire en premier lieu! Conservez cette notice! Modifications techniques sans préavis! Si vous avez des questions, veuillez contacter le fabricant.

IT Istruzioni di montaggio

Nota importanti. Si prega di leggere prima! Conservare le istruzioni! Modifiche tecniche senza preavviso! Per chiarimenti rivolgersi al produttore.

ES Instrucciones de montaje

Notas importantes. Por favor, lea primero! ¡Guarde las instrucciones! ¡Reservado el derecho de realizar modificaciones técnicas sin preaviso! Si tiene alguna pregunta, póngase en contacto con el fabricante.

NL Montagehandleiding

Belangrijke informatie. Gelieve eerst te lezen! Houd deze gebruiksaanwijzingen zorgvuldig bij! Technische wijzigingen blijven voorbehouden! Als u vragen hebt, kan u contact opnemen met de fabrikant.

SV Installationsanvisning

Viktigt information. Läs först! Spara anvisningen! Med reservation för tekniska ändringar! Om du har frågor ber vi dig ta kontakt med tillverkaren.

FI Asennusohje

Tärkeä huomautus. Lue ensin! Säilytä käyttöopas! Oikeudet teknisiin muutoksiin pidätetään! Lähetä mahdolliset kysymykset valmistajalle.

RU Инструкция по монтажу

Важная информация. Просьба ознакомиться перед началом работ! Сохраняйте инструкцию! Компания сохраняет за собой право на внесение технических изменений. При возникновении вопросов обращайтесь к производителю.

PL Instrukcja montażu

Ważne wskazówki/ uwagi. Proszę pierwsze przeczytać całość instrukcji. Proszę zachować instrukcję! Zastrzega się prawo do wprowadzania zmian technicznych. W razie pytań skontaktuj się z producentem.

ZH 安装说明

重要提示。请先阅读! 保留本说明! 请勿执行技术变动! 如有问题, 请咨询制造商。

AR

تعليمات التركيب

ملاحظات هامة. يرجى القراءة أولاً!

إبقاء التعليمات!

تخضع المواصفات للتغيير دون تقديم إشعار!

إذا كان لديك أسئلة، الرجاء الاتصال بالشركة المصنعة.



L12/L15

L15	1512 mm	max. 7,5 kg
L12	1264 mm	max. 6,5 kg

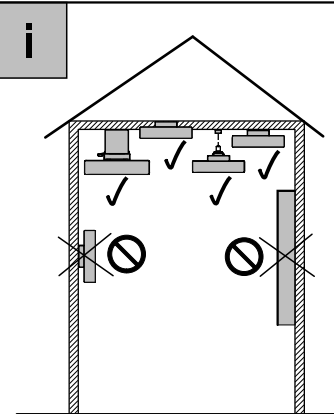
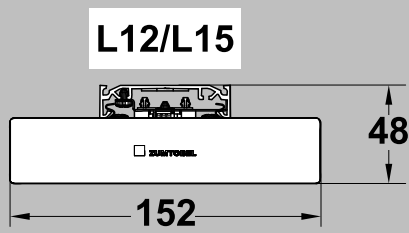
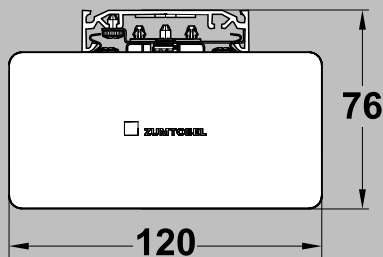

i

MOUNTING OPTIONS

A
surface-mounted



B
pendant

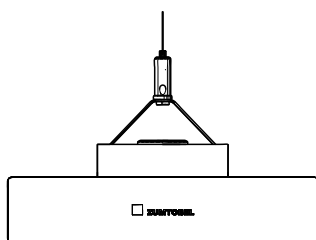

C
semi-recessed

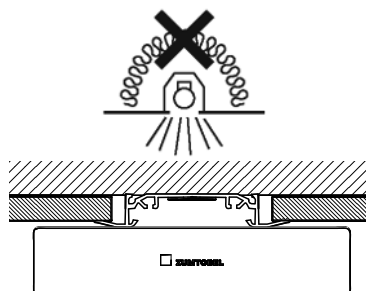

D
TECTON

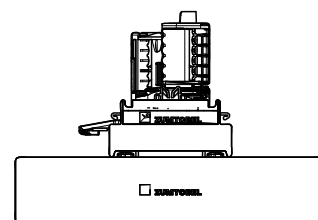

A B C

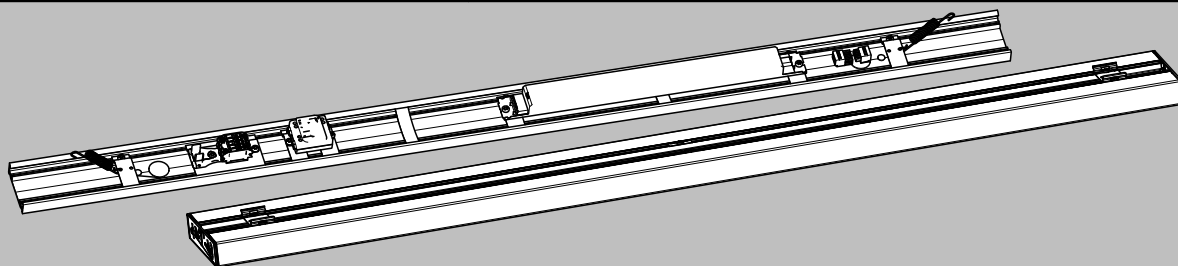

A B C D



BOX 22171129
22171130
22171131
22171132

Slim 22171133
22171134
22171135
22171136

2x

2x

1x

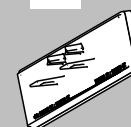

2x



A B C



22171139
22171140
22171141
22171142

22171143
22171144

1x



2x

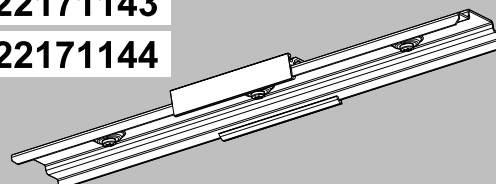

B



WH
1m 22171137
3m 22171138

1x



2x

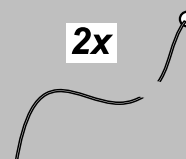

1x



1x

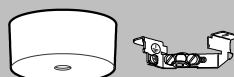

1x

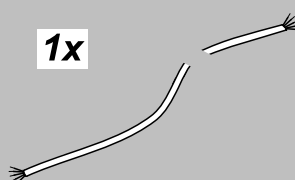

2x

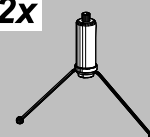

1x



4x



i

OPTION!



1,5 mm² max. 6A

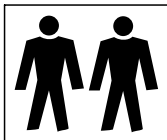

OPTION:
Emergency Lighting
pages 4+9/10+15+17

A B C

single luminaire



A2/B3/C2
A4/B4/C4

B2

A8/B8/C8

A1/B1/C1

OPTION!
A2/B3/C2

(A5)/(B5)/(C5)

A2/C2

A9

A7/B7/C7

DATE: XX.XX.XXXX
Counter: X

A10/B10/C10

A11/B11/C11

A6/B6/C6

continuous row

D

D3_{2x}

D1

(D2)

D4

D5

pages 15-17

A B C

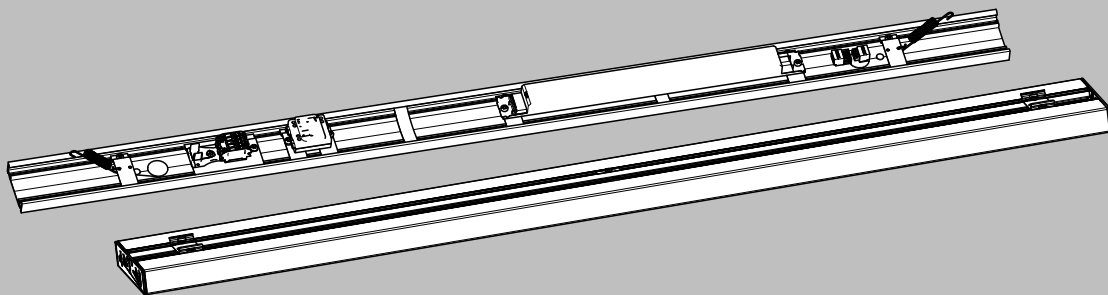
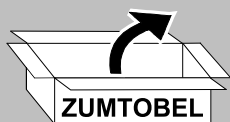

i A B

(L15) 1130 mm
(L12) 882 mm

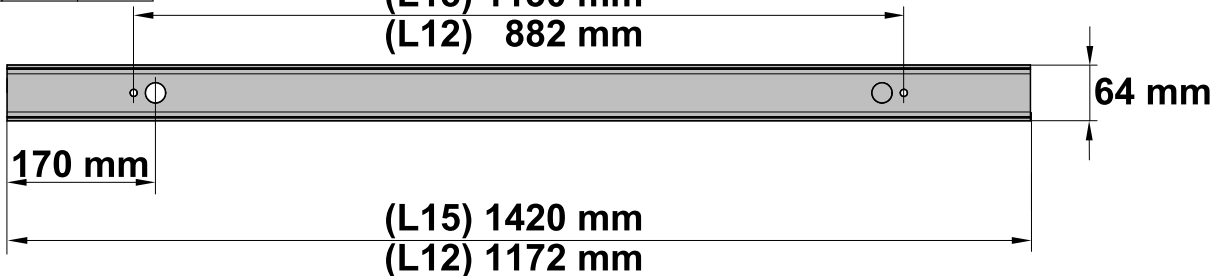

i C

(L15) 1130 mm
(L12) 882 mm

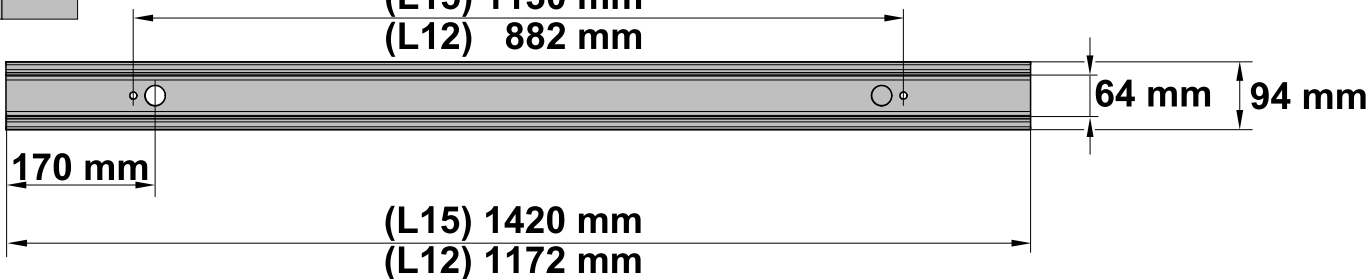

A1 B1 C1

! Emergency Lighting

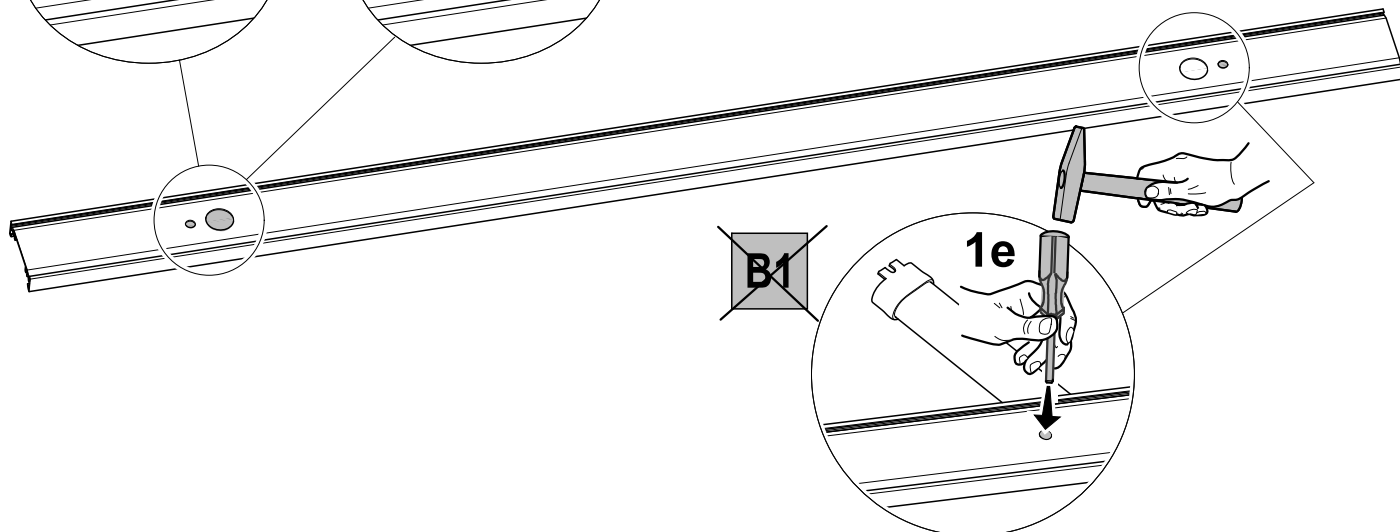
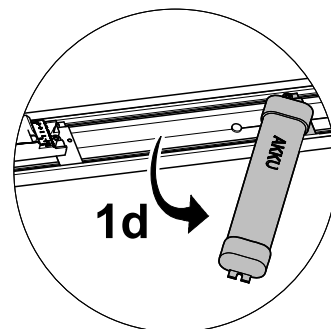
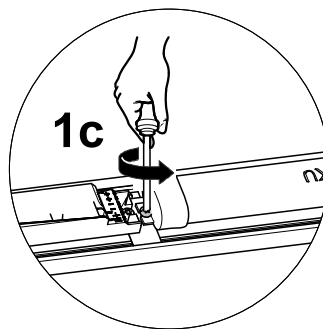
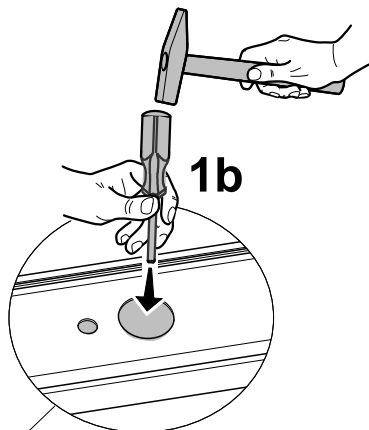
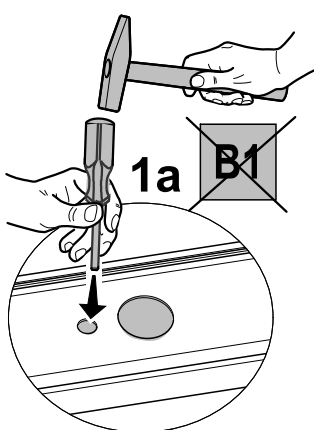

A2



1x

2x

2a

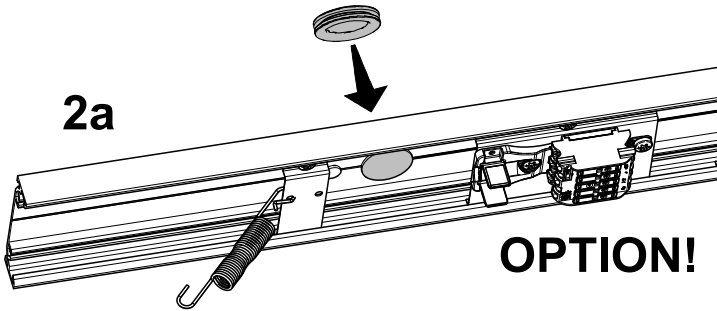

2c
2x

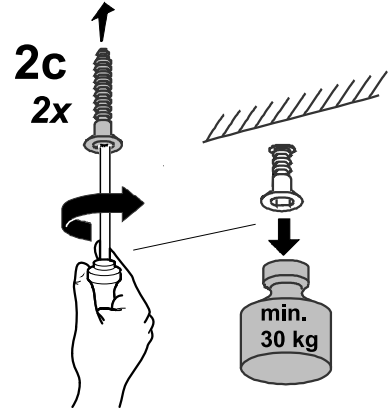

2b
2x

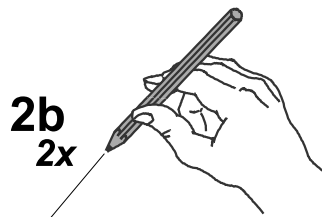

(L15) 1130 mm
(L12) 882 mm

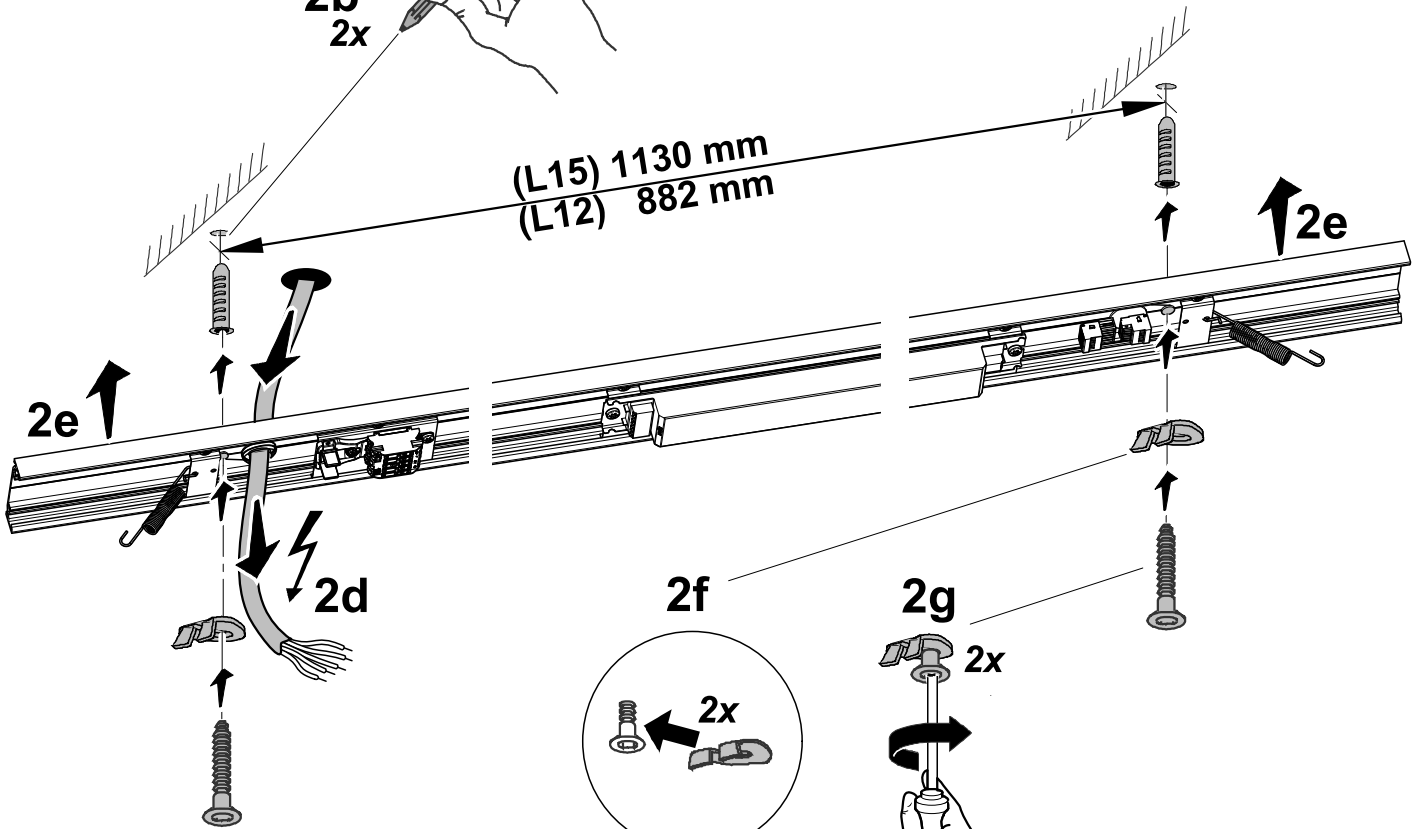

B2.3

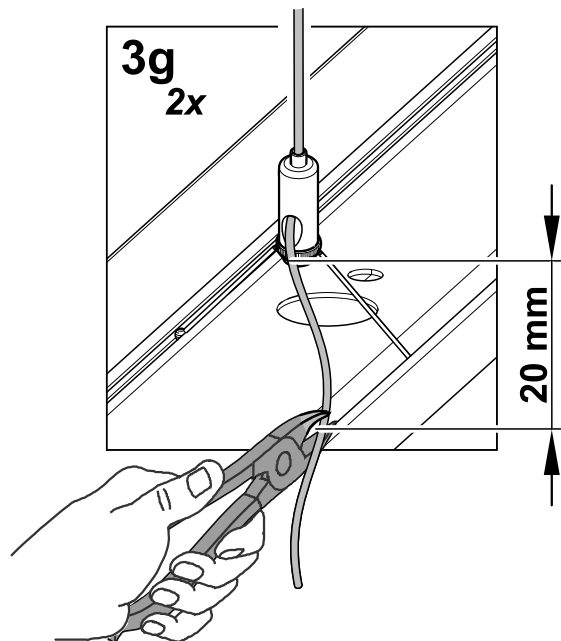
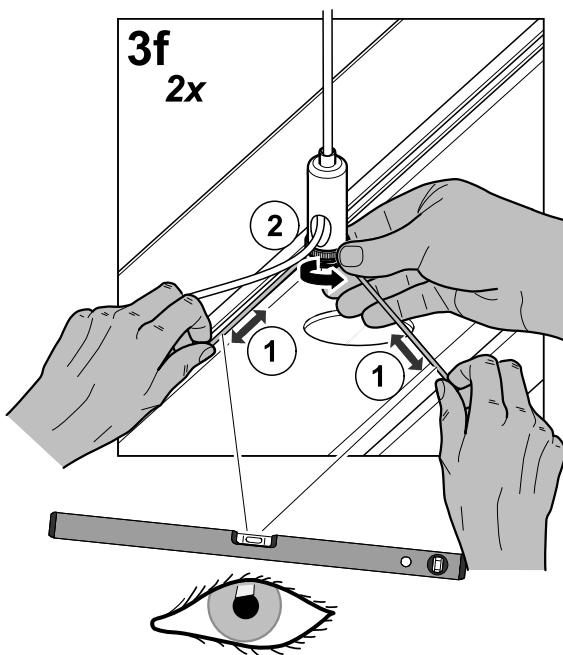
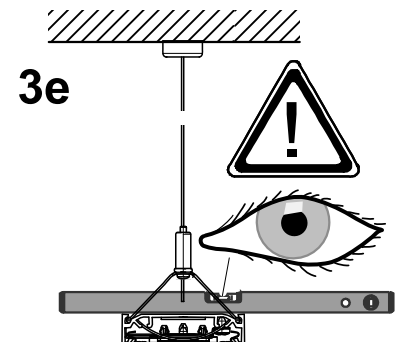
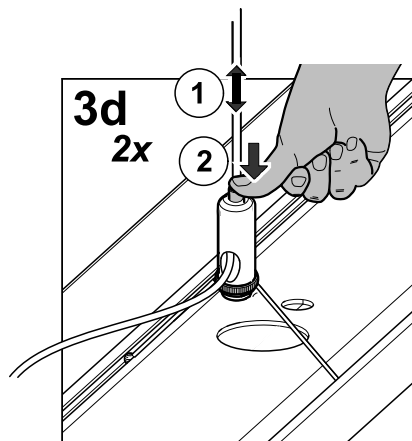
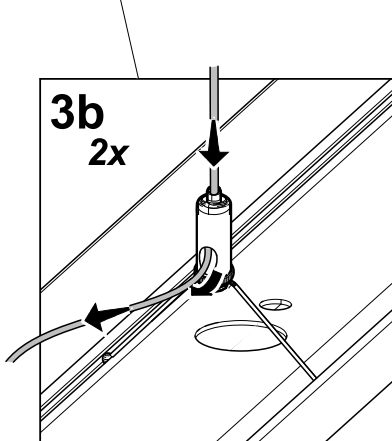
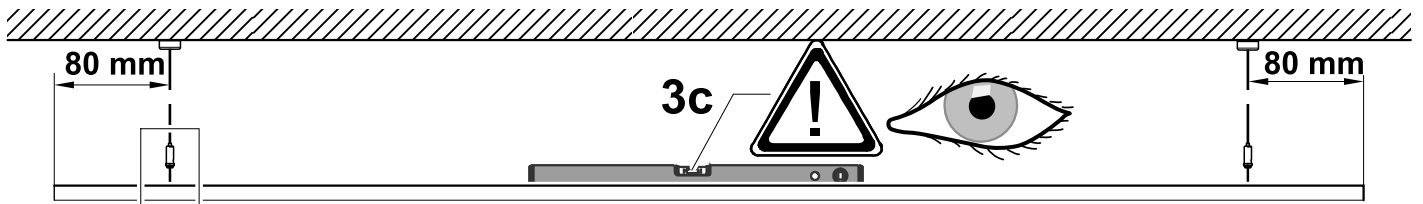
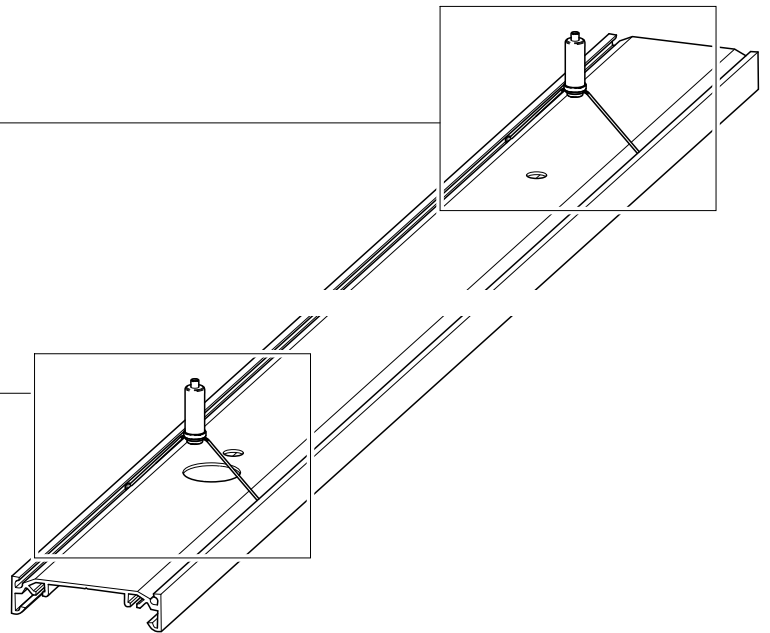
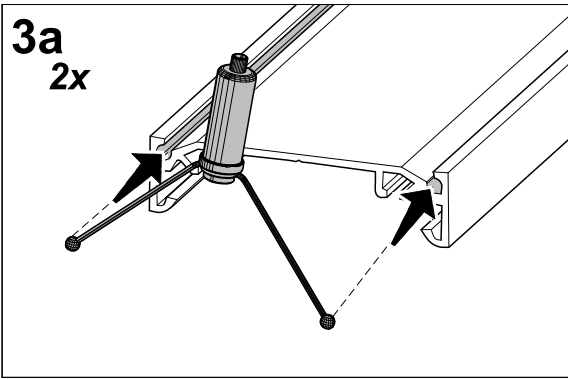

C2

i



2x

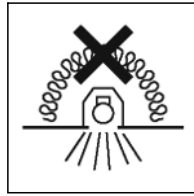

min. 66 mm
max. 72 mm

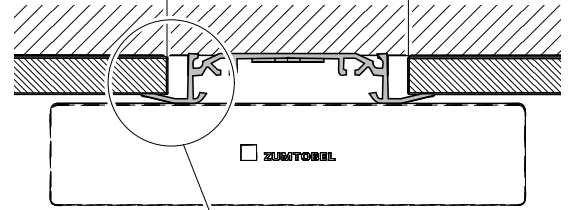

2b
2x

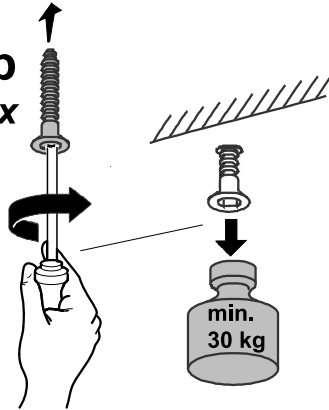

16 mm

12,9 mm

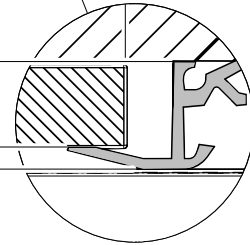

2a
2x

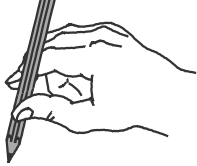

(L15) 1423 ⁺¹₋₀ mm

(L12) 1175 ⁺¹₋₀ mm

(L15) 1130 mm
(L12) 882 mm

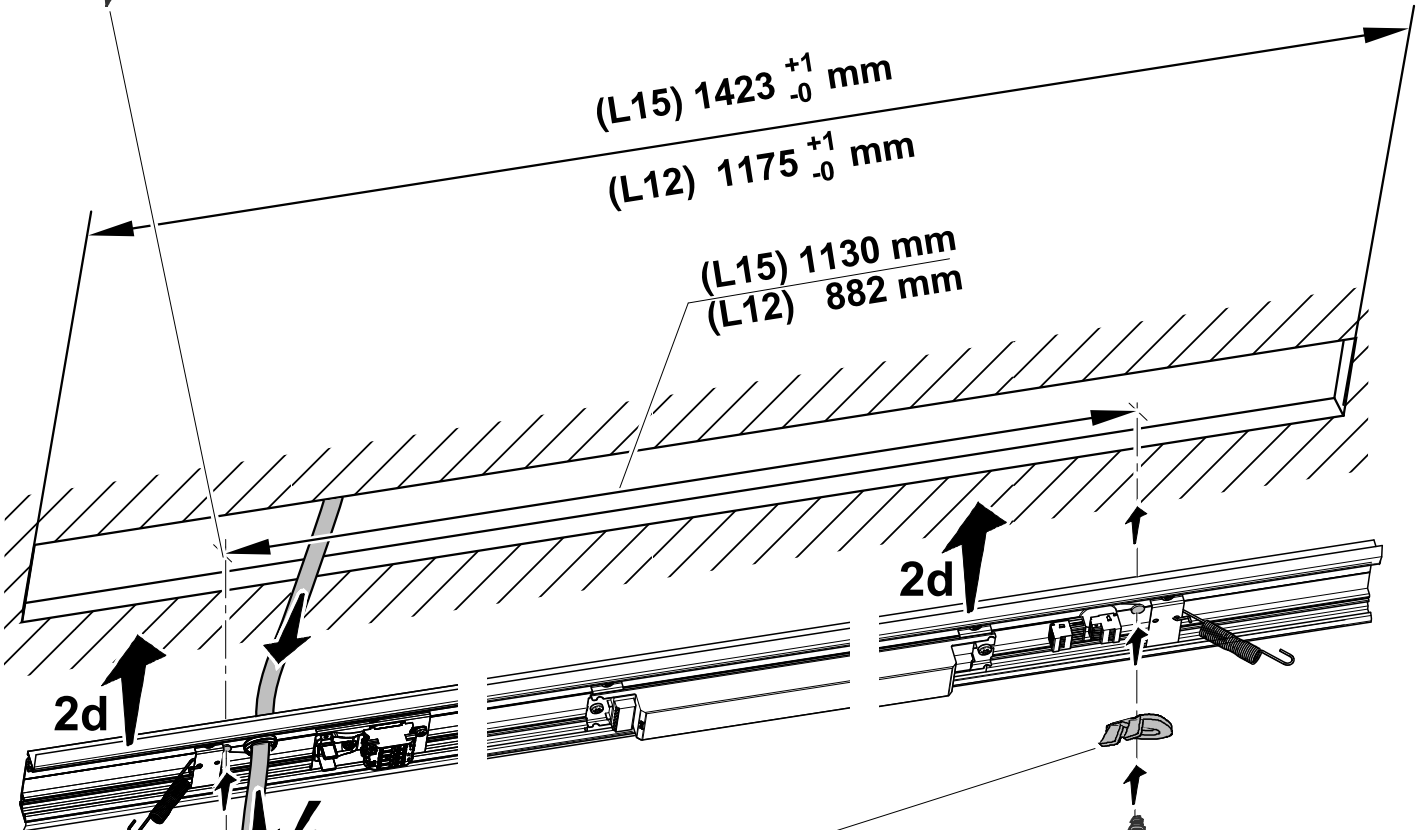

2d

2d

2c

2e

2f

2x

2x

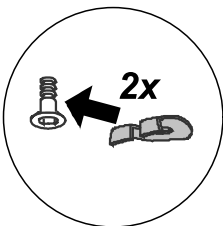

~~A3~~ ~~B3~~ ~~C3~~



1x

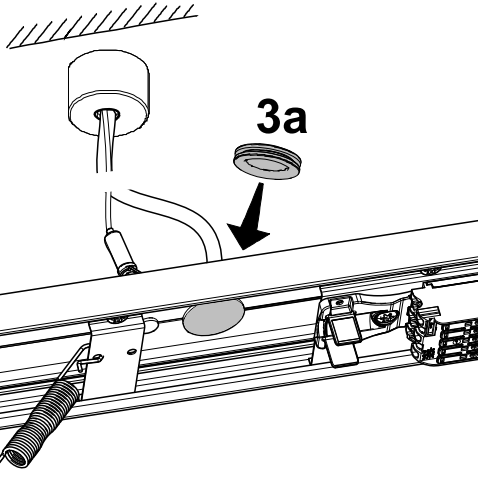

3a

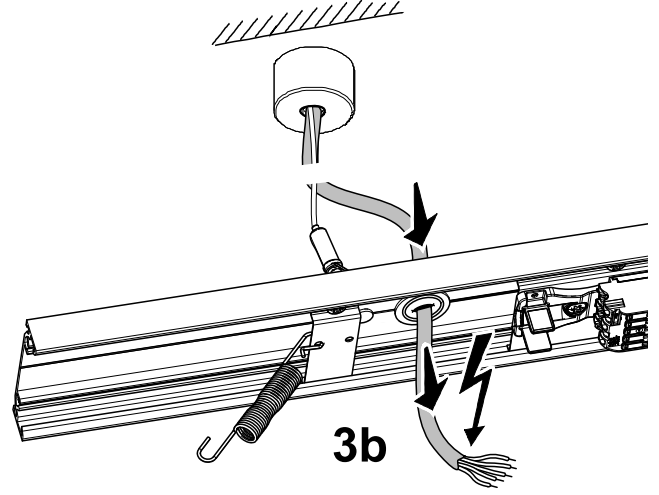

3b

i OPTION: A3 B3 C3

3 pin-cable
3 pol-Kabel
+ 2 pin-cable
2 pol-Kabel

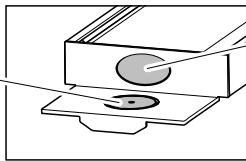

5 pin-cable
5 pol-Kabel

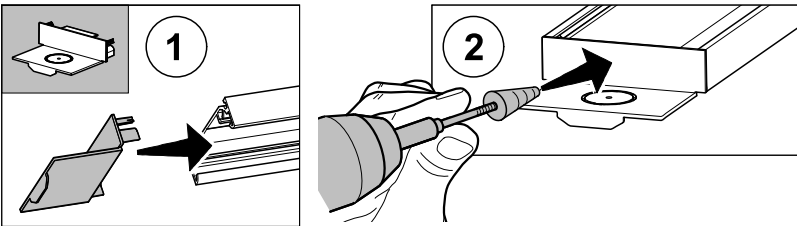

1

2

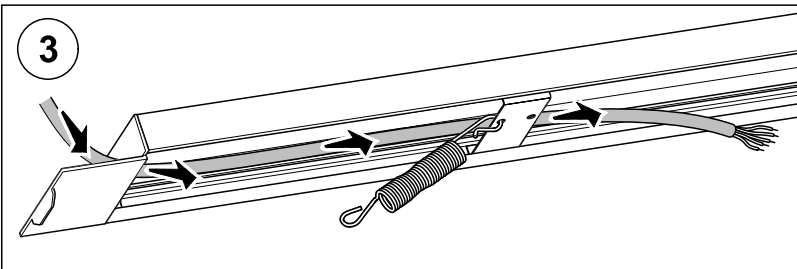

3

! Emergency Lighting

page 4

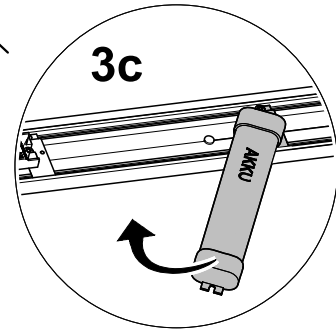

3c

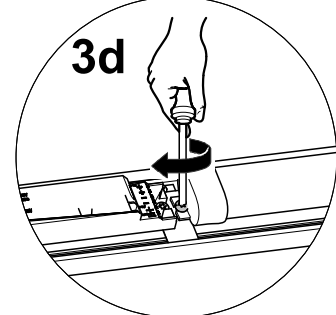

3d

A4 B4 C4 **i** ⚡

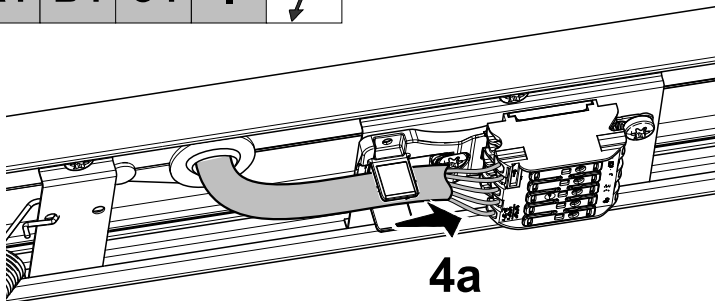

4a

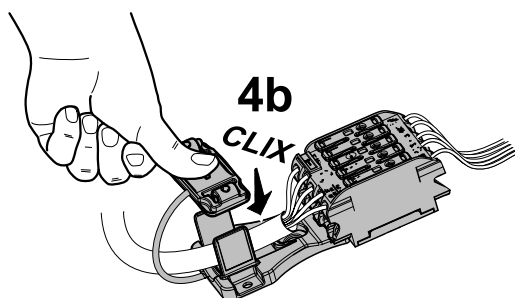

4b

CLIX



1,5 mm² max. 6A

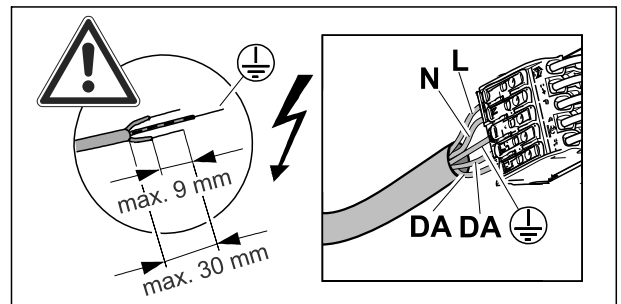

i  **OPTION: Emergency Lighting (self-contained)**

E3D

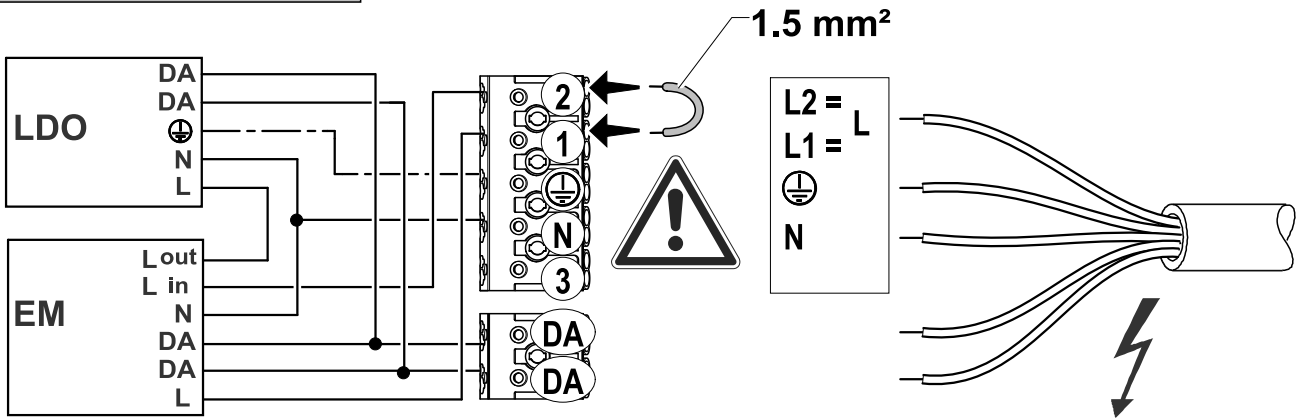

E3D UK ONLY

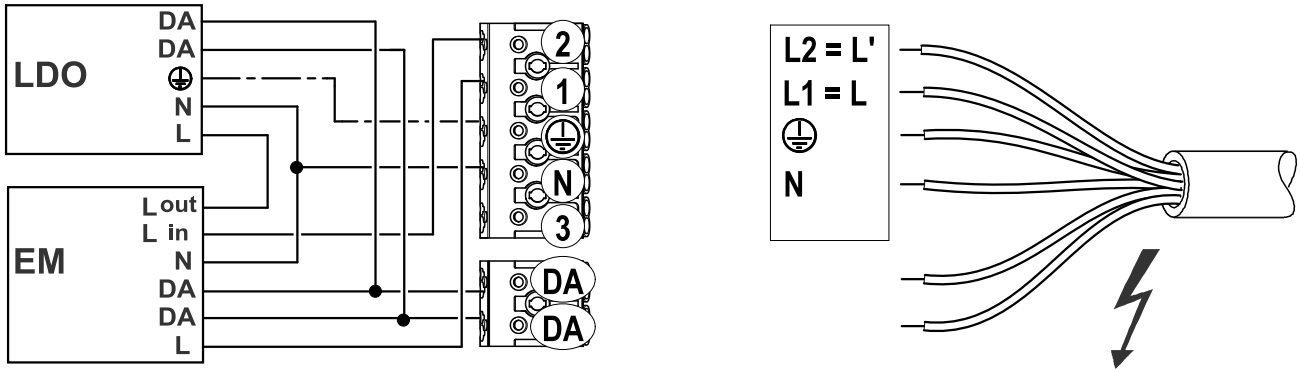

(A5)(B5)(C5) **i** 



(5a)

Commissioned Date:

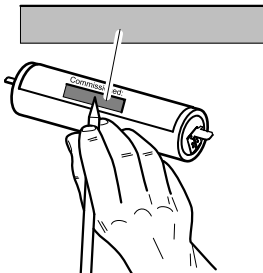

(5b)



BATTERY

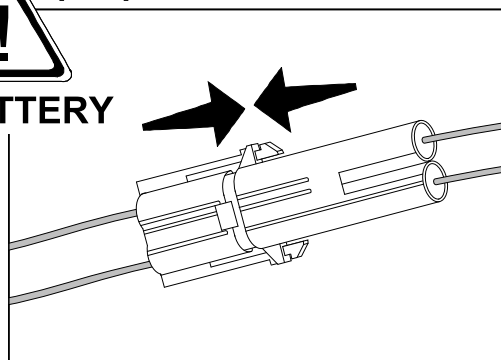

(5c)

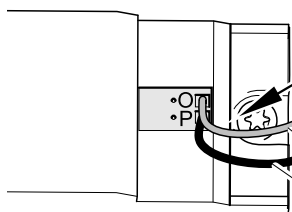

ROT/RED - O

SCHWARZ/BLACK - P

(5d)

GREEN / GRÜN

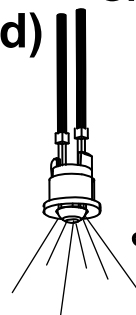

A6 B6 C6 continuous row

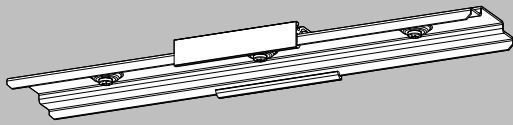

1x 2x

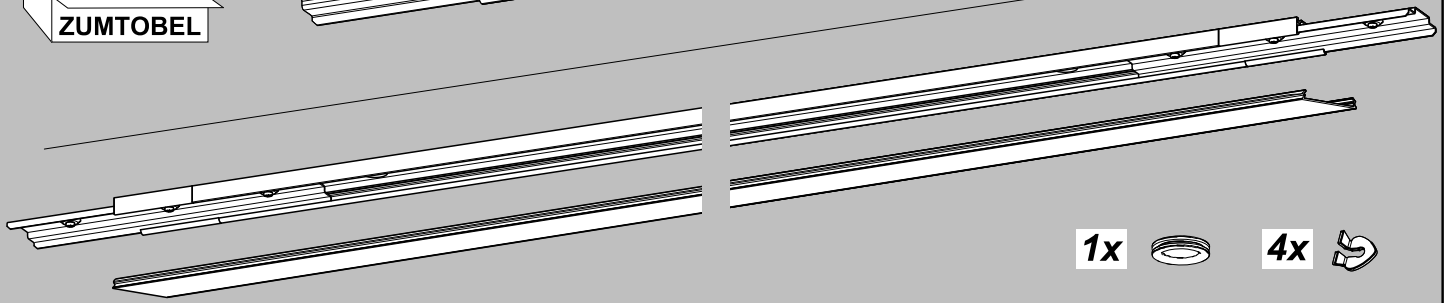

1x 4x

i

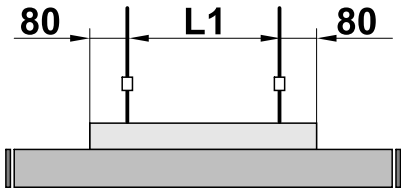

	L1	L2	L3	L4
L12	1014	1133	1251	1499
L15	1262	1381	1499	1499

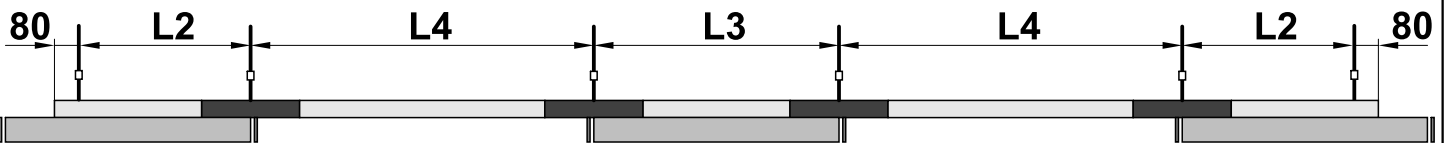
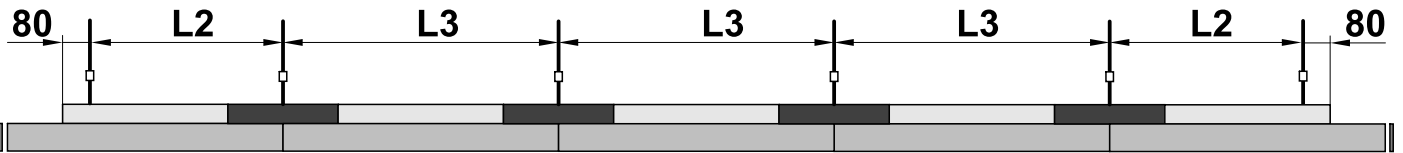

6a

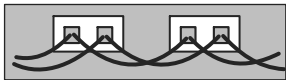

3x 1,5 mm² max. 6A

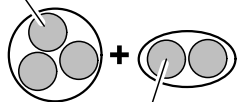

2x 1,5 mm² max. 6A



OPTION: ✓
5x 1,5 mm² max. 6A



(L12) 1330 mm

(L15) 1600 mm

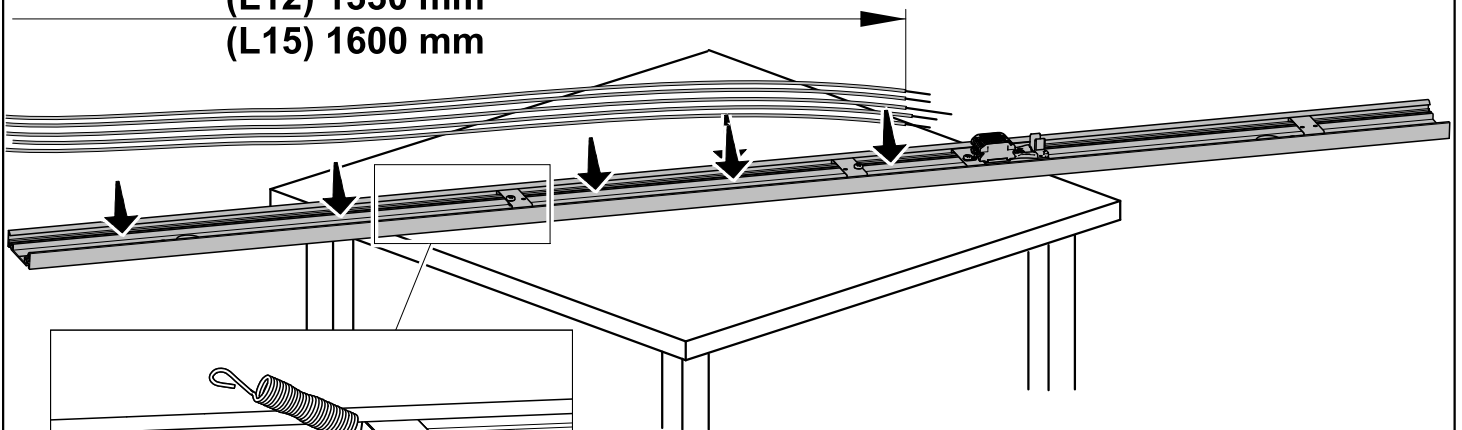

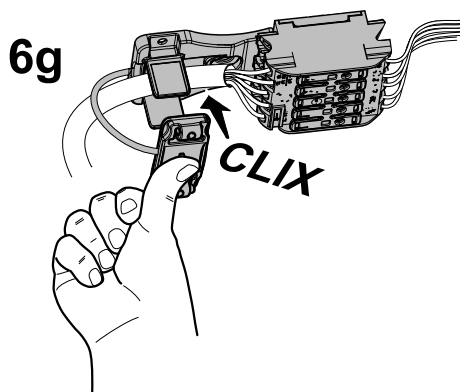
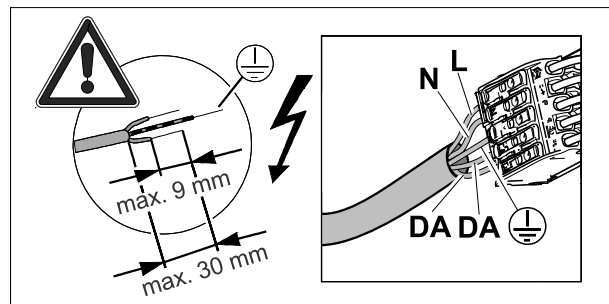
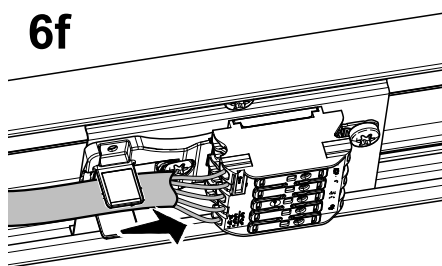
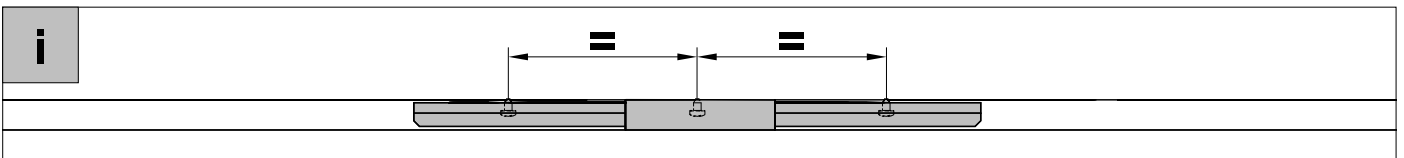
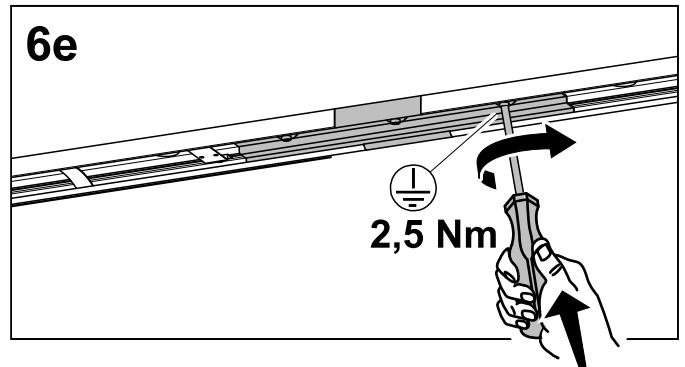
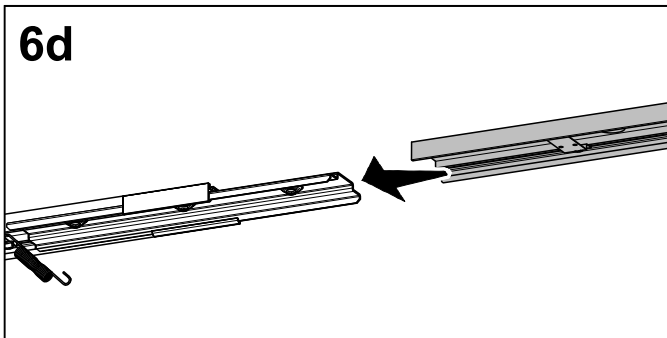
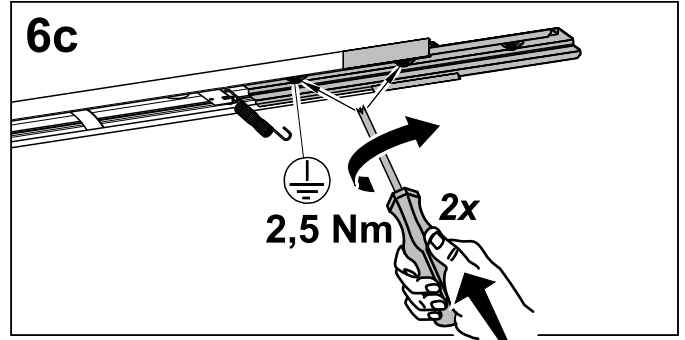
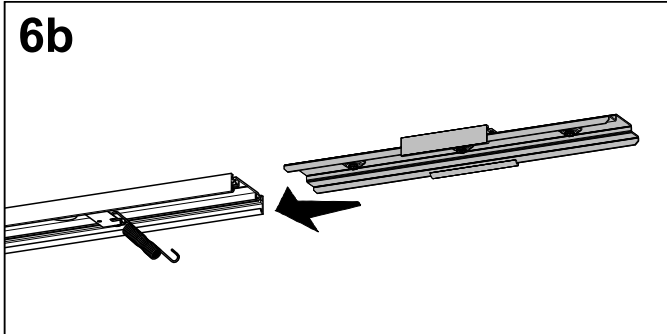
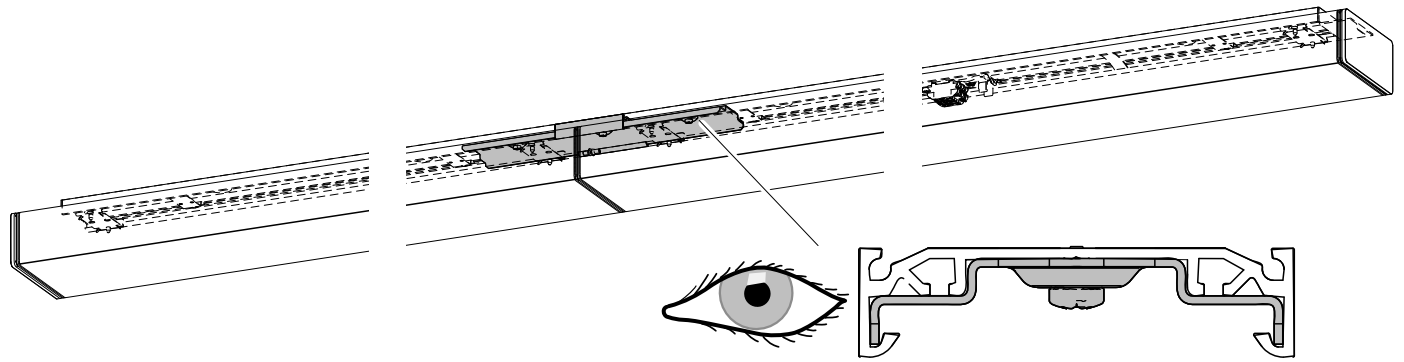

A7 B7 C7

DATE: XX.XX.XXXX

Counter: X

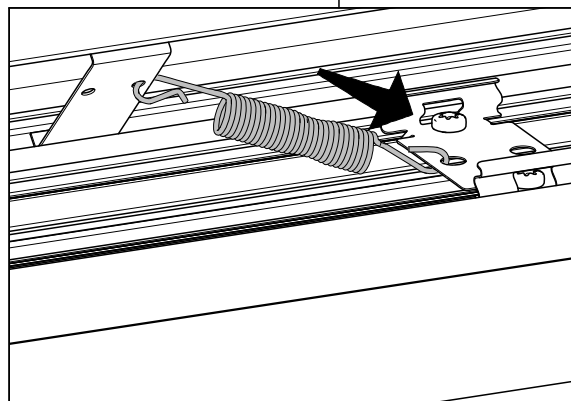
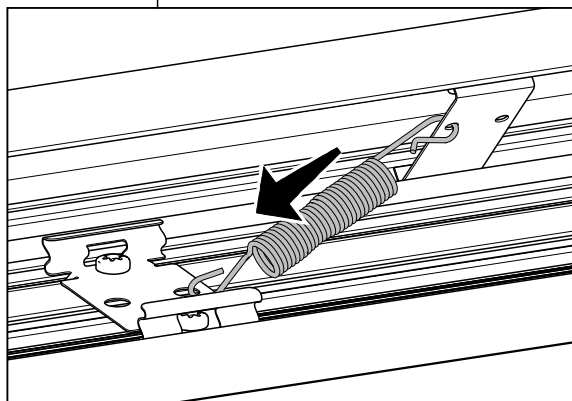
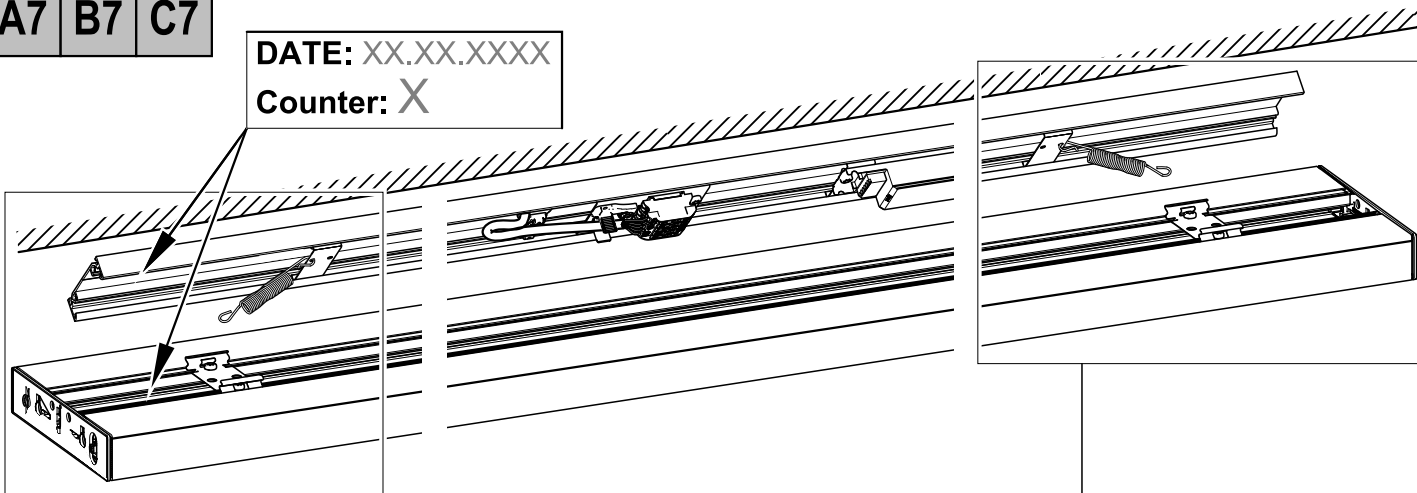

A8 B8 C8

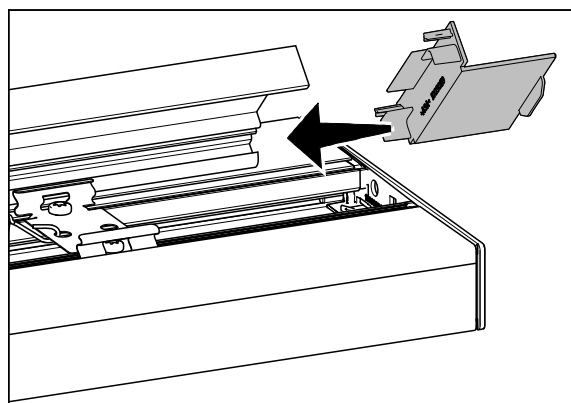
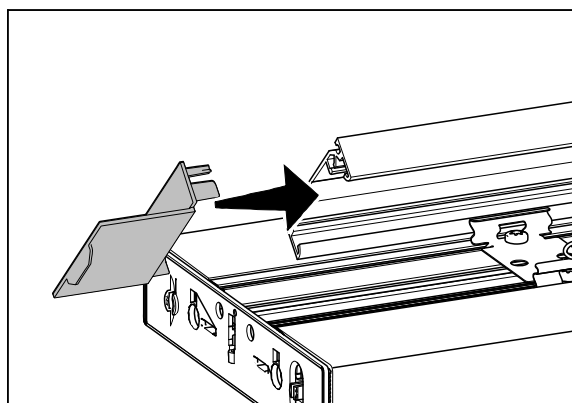
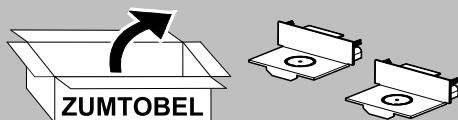

A9 B9 C9

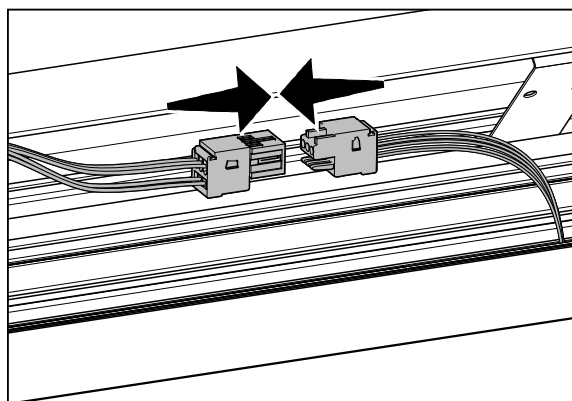

A10B10C10

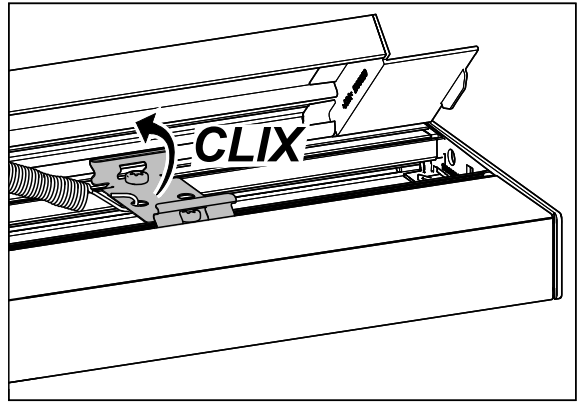
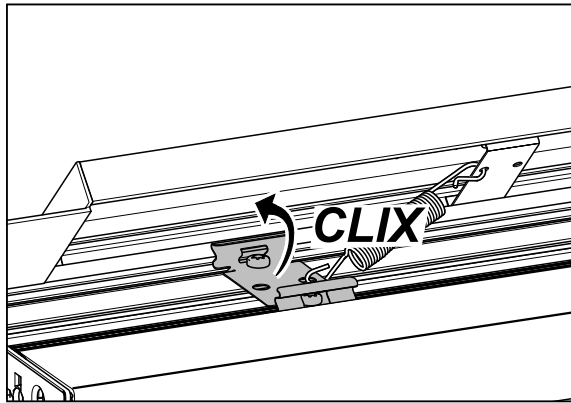

A11B11C11 ✓

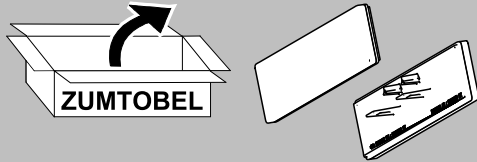

single luminaire

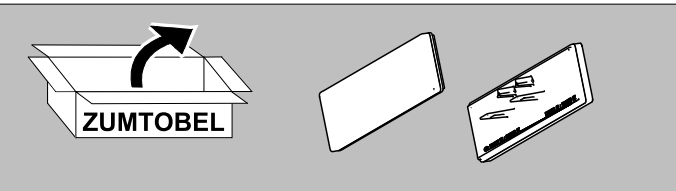
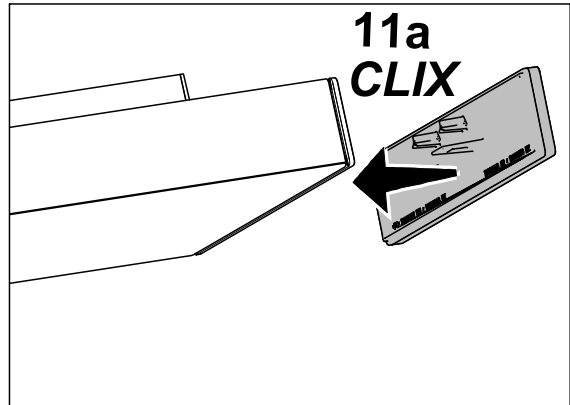
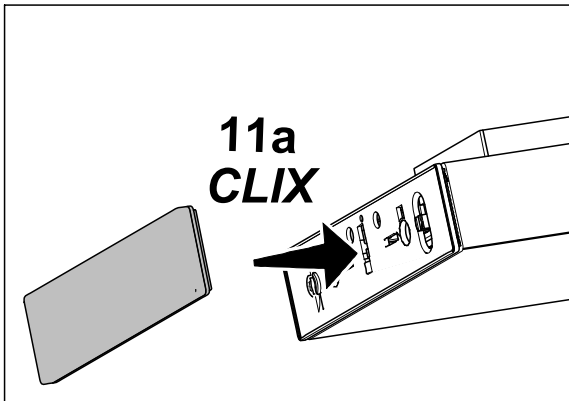

continuous row

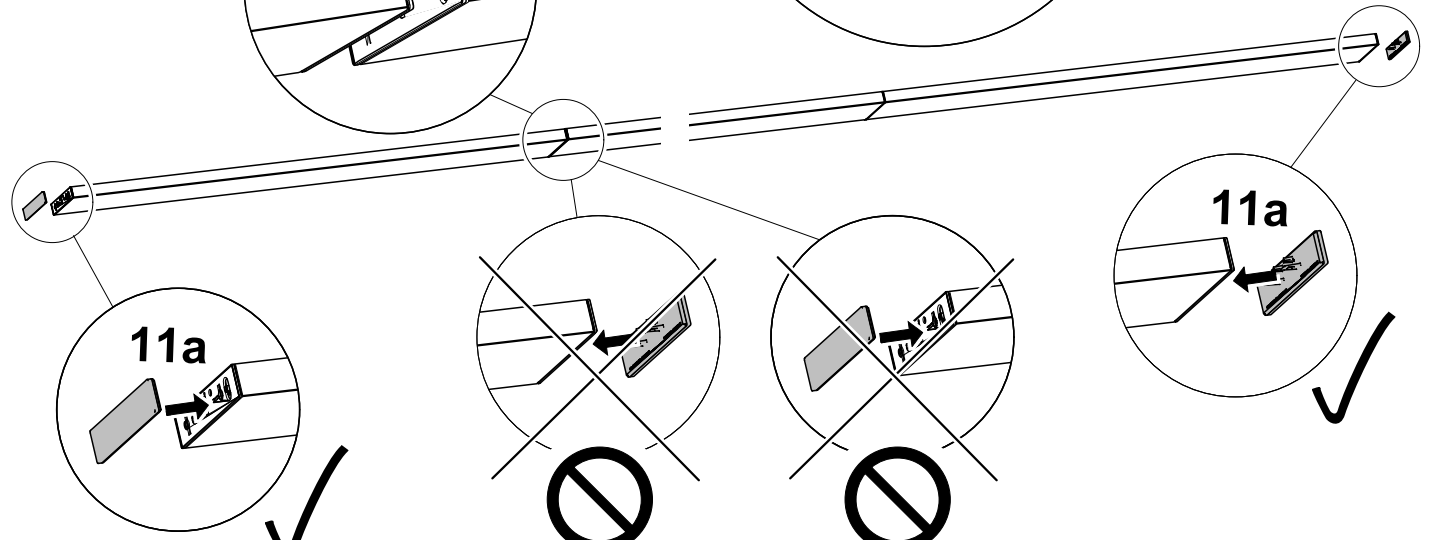
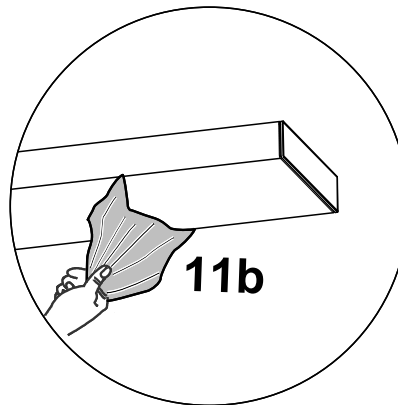
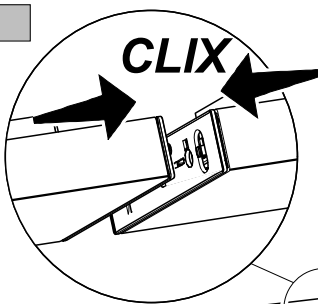

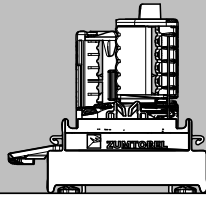
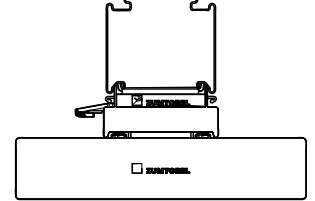
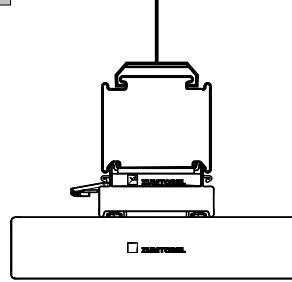
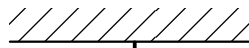
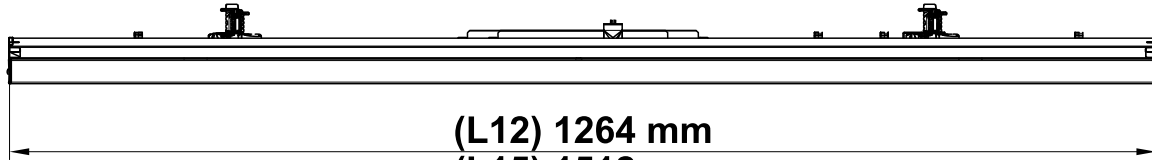
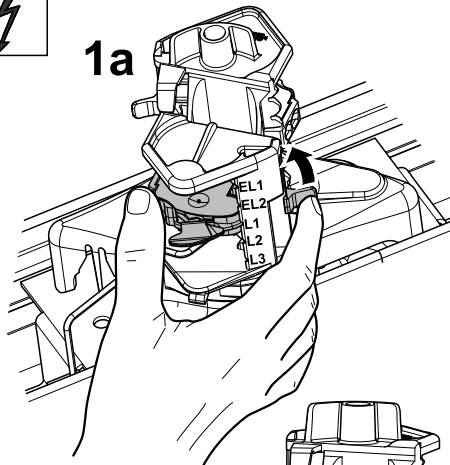
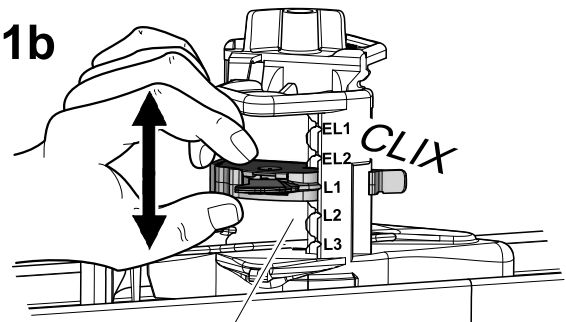
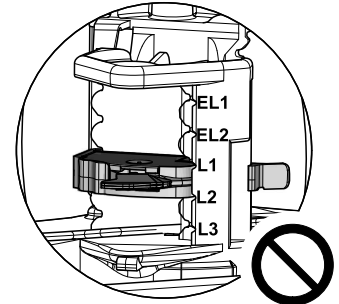
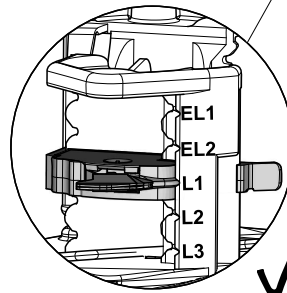
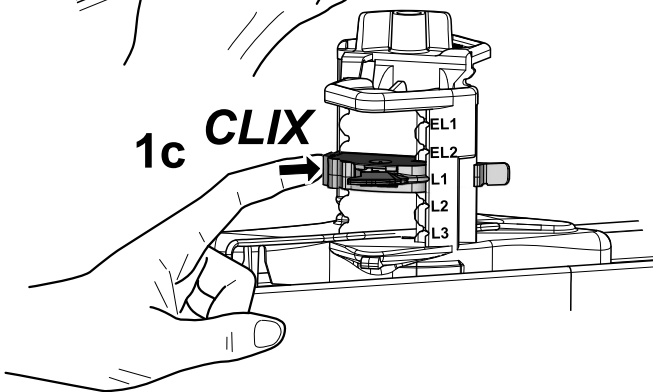
D**i****i****(L12)** 1264 mm**(L15)** 1512 mm**D1****1a****1b****1c****CLIX**

(D2) i ⚡ **OPTION: Emergency Lighting (self contained)**

(2a)

Commissioned Date:

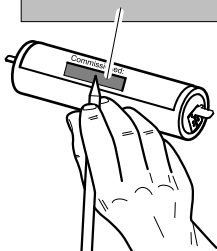
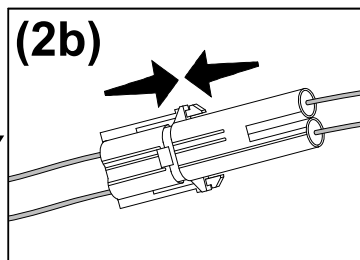
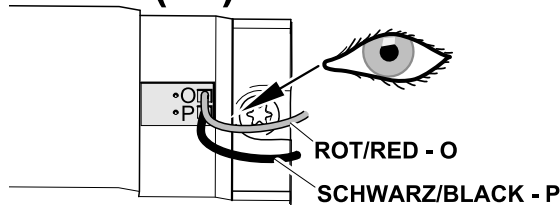
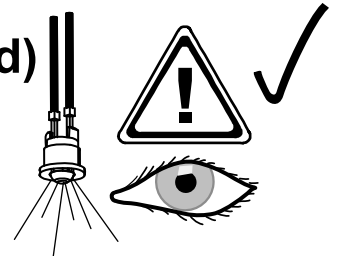
**BATTERY****(2b)****(2c)****GREEN / GRÜN****(2d)**

D3

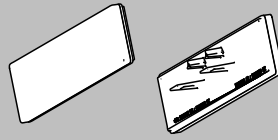
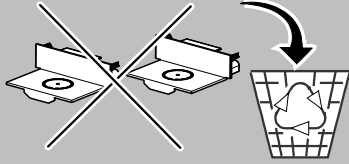

single luminaire

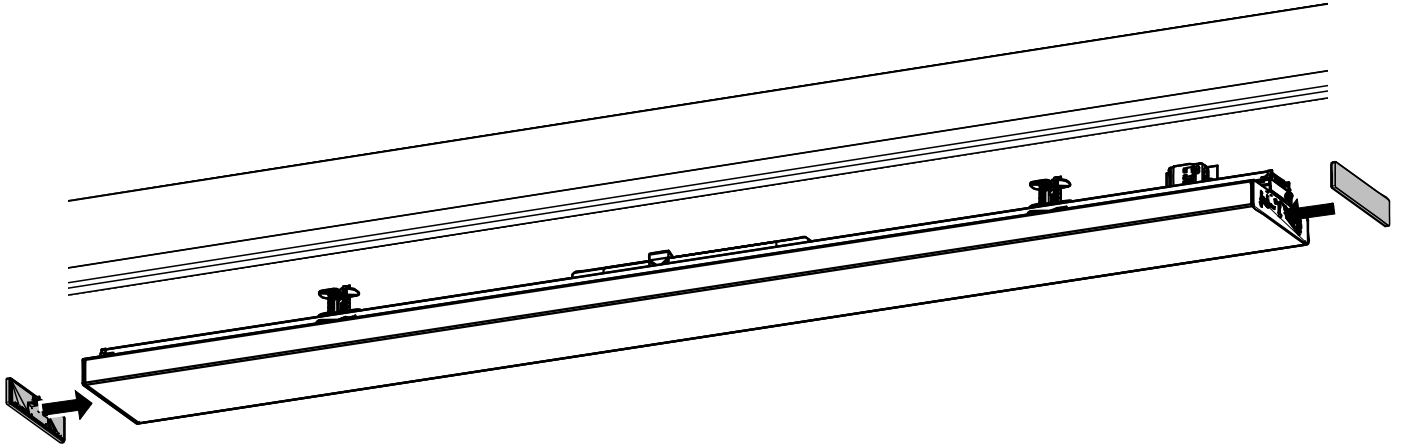

continuous row

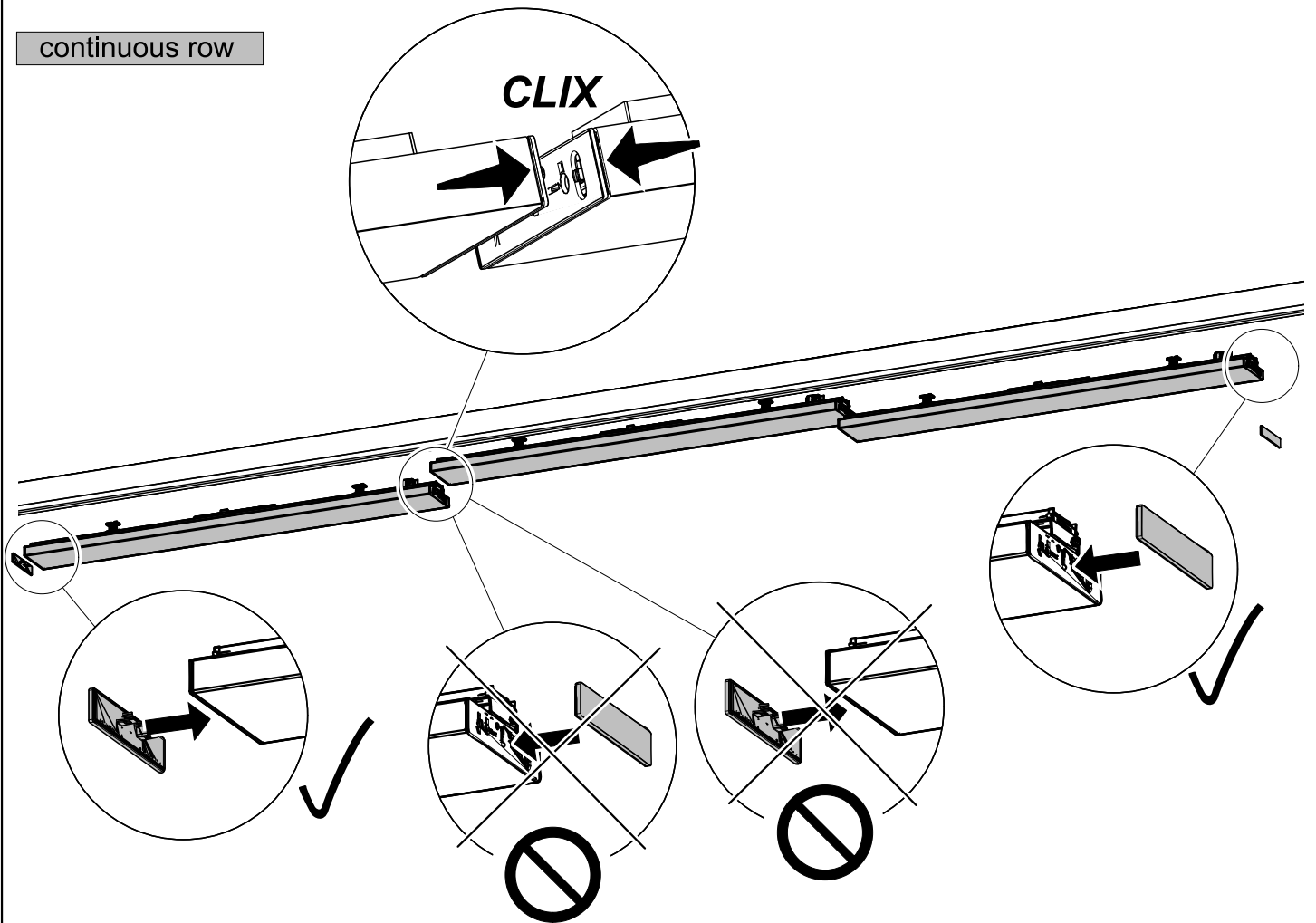

D4

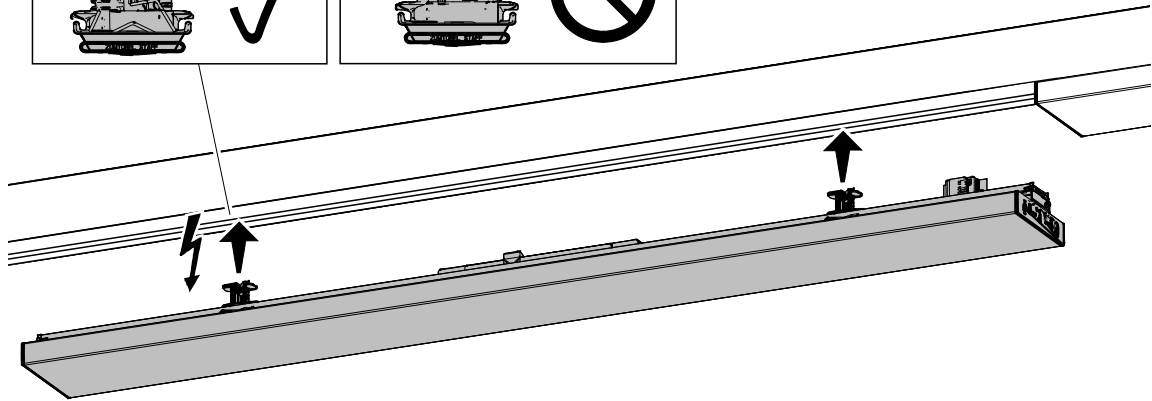
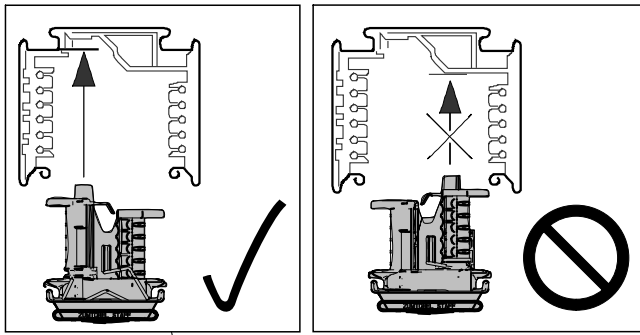

D5 ✓

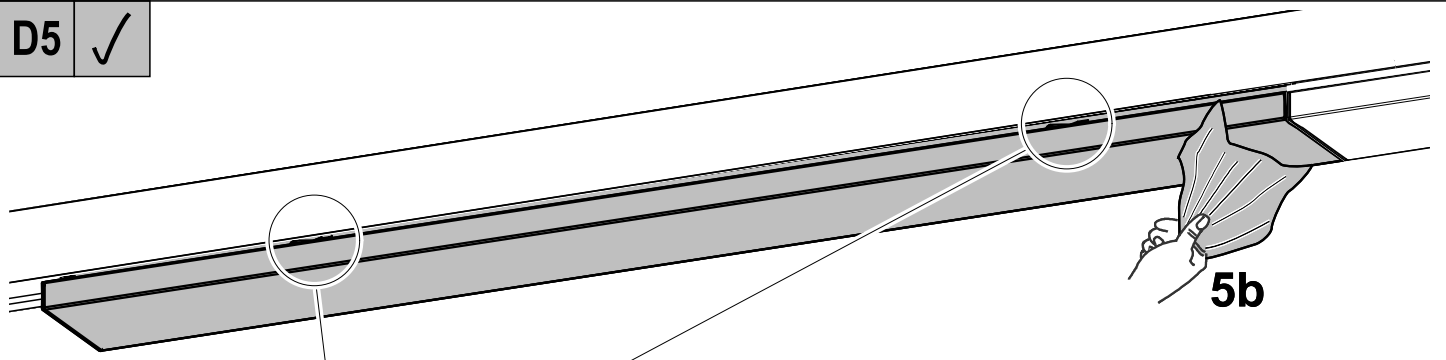

5a

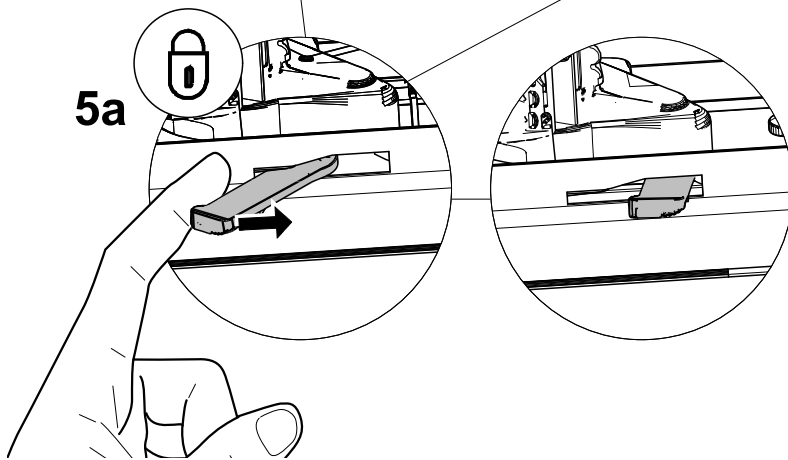

i

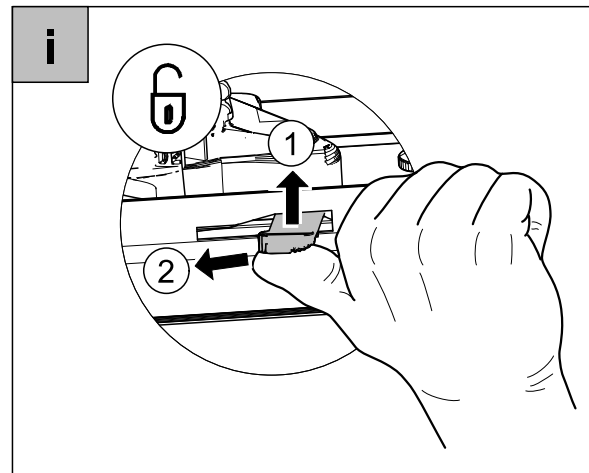

A B C D i ⚡ OPTION: Emergency Lighting (centrally supplied)

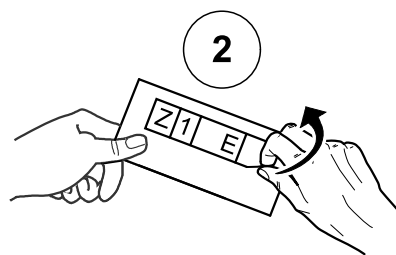
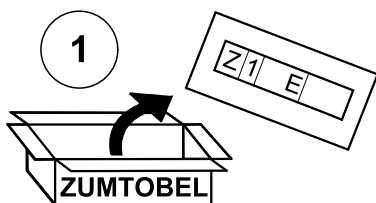

Chemische Beständigkeit beachten. Nur kunststoffverträgliche Reinigungsmittel verwenden.
Note: Due to problems with chemical resistance, choose cleaning materials which are suitable for plastic.
Respectez la résistance chimique du matériel: n'utilisez que des détergents compatibles avec les matières synthétiques.
Rispettare la resistenza chimica del materiale: utilizzare solo detersivi compatibili con materiali plastici.
Rekening houden met chemische weerstand. Gelieve enkel reinigingsmiddelen te gebruiken die Kunststoffvriendelijk zijn.

DE Hinweise für die Montage und den Betrieb!

Die Montage und Inbetriebnahme der Leuchte sowie jede Veränderung an der Leuchte darf nur von autorisierten Fachkräften (qualifizierter Elektriker) durchgeführt werden. Die nationalen Errichterbestimmungen sind zu beachten. Vor jeder Arbeit an der Leuchte ist diese vom Netz zu trennen.

Hot Plug-in ist nicht möglich und kann zu Schäden an der Leuchte führen!

Der Hersteller haftet nicht für Schäden, die aus fehlerhafter Montage, aus unsachgemäßem Betrieb oder unautorisierten Veränderungen an der Leuchte resultieren.



Die Lichtquelle dieser Leuchte ist nicht ersetzbar; wenn die Lichtquelle ihr Lebensdauerende erreicht hat, ist die gesamte Leuchte zu ersetzen. Bei beschädigtem Abschlussglas ist ebenfalls die gesamte Leuchte zu tauschen. **Vorsicht, Gefahr eines elektrischen Schlags.**

Technische Änderungen vorbehalten! Bei Fragen wenden sie sich an den Hersteller.

EN Instructions for installation and operation!

The installation and commissioning of the luminaire as well as any modification to the luminaire may only be performed by authorized personnel (qualified electrician). National installation regulations must be observed. Before any work on the appliance is done, it must be disconnected from mains.

Hot plug-in is not an option and may cause damage to the lamp or luminaire!

The manufacturer is not liable for damages resulting from improper or faulty installation or operation or from unauthorized modifications to the luminaire.



The light source of this luminaire is not replaceable; when the light source reaches its end of life the whole luminaire shall be replaced. If the cover glass is damaged also the whole luminaire needs to be replaced. **Caution, risk of electric shock!**

Specifications are subject to change without notice! If you have questions, please contact the manufacturer.

FR Instructions pour l'installation et l'utilisation!

L'installation et la mise en service du luminaire ainsi que toute modification au luminaire doivent être effectuées par un personnel autorisé (électricien qualifié). Les règles nationales d'installation doivent être respectées. Avant toute intervention sur l'appareil, il doit être débranché de son alimentation.

Le branchement à chaud est interdit, et peut endommager à la lampe ou le luminaire!

Le fabricant décline toute responsabilité pour les dommages résultant d'une mauvaise installation ou opération, ou d'une modification non autorisée du luminaire.



La source lumineuse de ce luminaire n'est pas remplaçable; lorsque la source lumineuse atteint sa fin de sa vie, le luminaire entier doit être remplacé. Si la glace de fermeture est endommagée, le luminaire entier doit également être remplacé. **Avertissement, risque de choc électrique.**

Sous réserve de modifications des spécifications techniques! Pour toute question, contactez le fabricant.

IT Istruzioni per l'installazione e il funzionamento!

L'installazione e la messa in servizio degli apparecchi, nonché qualsiasi modifica dell'apparecchio può essere eseguita solo da personale autorizzato (elettricista qualificato). Le norme nazionali di installazione devono essere rispettate. Prima di qualsiasi intervento sull'apparecchio, questo deve essere scollegato dalla rete.

Non è possibile un Hot Plug In e può causare danni alla lampada o all'apparecchio!

Il produttore non si assume alcuna responsabilità per i danni derivanti da un'installazione impropria o difettosa, o per modifiche non autorizzate apportate all'apparecchio. La sorgente luminosa di questo apparecchio



non è sostituibile; quando la sorgente luminosa raggiunge il termine di vita, l'intero apparecchio deve essere sostituito. Se il vetro è danneggiato, l'intero apparecchio deve essere sostituito.

Attenzione, rischio di shock elettrico! Modifiche tecniche sono soggette a cambiamenti senza preavviso! Se avete domande, si prega di contattare il produttore.

NL Aanwijzingen voor installatie en bediening!

De installatie en inbedrijfstelling van het armatuur, alsook elke wijziging in of aan het armatuur mogen alleen door bevoegd personeel (elektricien) worden uitgevoerd. De nationale installatie voorschriften moeten worden nageleefd. Voor alle werkzaamheden aan het apparaat, moet deze worden losgekoppeld van het net.

Hot plug-in is niet mogelijk en kan schade aan de lichtbron of het verlichtingstoestel veroorzaken!

De fabrikant is niet aansprakelijk voor schade als gevolg van onjuiste of foutieve installatie, bediening of schade welke het gevolg zijn van niet geautoriseerde wijzigingen aan het armatuur. De lichtbron van dit



armatuur is niet vervangbaar; indien de lichtbron aan het einde van zijn levensduur is, dient het gehele armatuur vervangen te worden. Indien het afdekglas beschadigd is, dient het gehele armatuur ook vervangen te worden. **WAARSCHUWING: Gevaar voor elektrische schokken.**

Technische wijzigingen voorbehouden! Als u vragen hebt, kunt u contact opnemen met de fabrikant.