

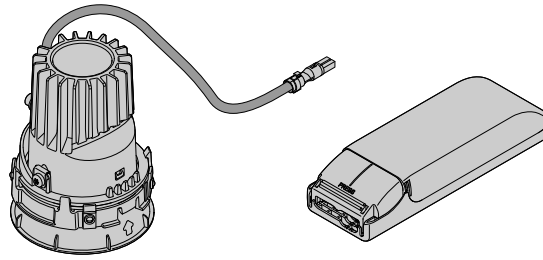

Typ-Nr. E14497

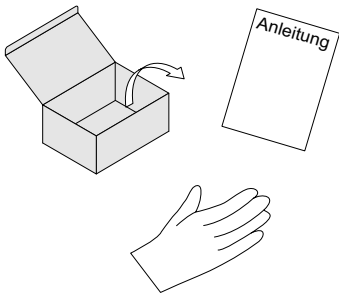

 **ZUMTOBEL**
 Mod
 Ser
 Typ
 ... W LED ...mA

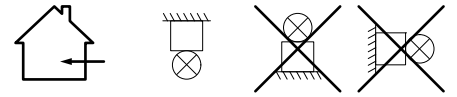

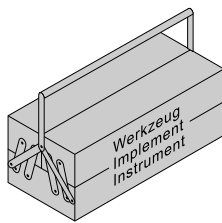
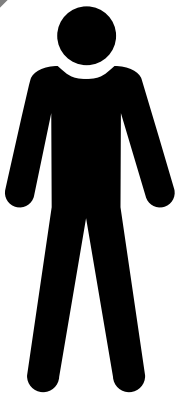
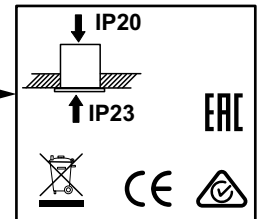
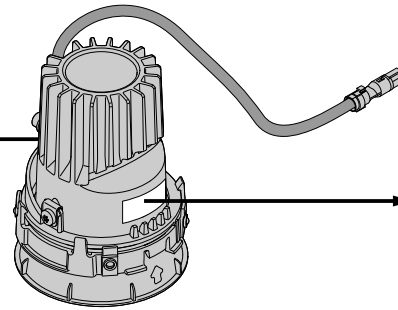
DE Die Montage und Inbetriebnahme darf nur von autorisiertem Fachpersonal durchgeführt werden.

NL De montage en inbedrijfstelling mogen enkel door erkend vakpersoneel worden uitgevoerd.

GB Installation and commissioning may only be carried out by authorized specialists.

NO/SE Monteringen och idrifttagandet får endast företas av auktoriserad fackpersonal.

FR L'installation et la mise en service doivent obligatoirement être effectuées par des techniciens.

FI Asennuksen ja käyttöönoton saa tehdä vain auktorisoitu ammattihenkilöstö.

IT Montaggio ed avviamento devono essere eseguiti solo da personale specializzato.

ES El montaje y la puesta en marcha sólo puede ser realizado por personal especializado autorizado.

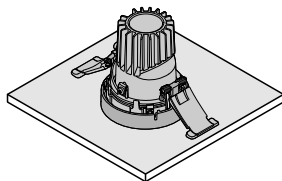

FR Le luminaire sert uniquement à l'éclairage et doit être installé conformément aux prescriptions nationales en matière d'installation. Toute autre utilisation ou installation est considérée comme "non conforme".

NO/SE Armaturen är uteslutande avsedd för belysning och ska installeras i enlighet med de nationella installationsbestämmelserna. All annan användning eller montering gäller som "icke ändamålsenlig".

DE Die Leuchte dient ausschließlich der Beleuchtung und ist entsprechend den nationalen Errichtungsbestimmungen zu installieren. Eine andere Nutzung oder ein anderer Einbau gilt als „nicht bestimmungsgemäß“.

IT L'apparecchio è destinato esclusivamente all'illuminazione e va installato in conformità alle leggi nazionali in vigore. Un altro impiego o un diverso tipo di montaggio non è considerato conforme alle disposizioni.

FI Valaisin on tarkoitettu ainoastaan valaistuskäyttöön, ja se on asennettava kansallisten määräysten mukaan. Muu käyttö tai muu asennus katsotaan sopimuksenvastaiseksi käytöksi.

GB The luminaire is used exclusively for lighting and is to be installed in accordance with the national installation regulations. Any other use or installation is regarded as "not according to instructions".

NL De lamp dient uitsluitend voor de verlichting en dient conform de nationale bouwvoorschriften te worden geïnstalleerd. Een ander gebruik of een andere inbouw is niet conform.

ES La lámpara está destinada exclusivamente a la iluminación y debe ser instalada de acuerdo con las pertinentes normas nacionales. Cualquier otro uso o instalación no se considerará "previsto por la norma".

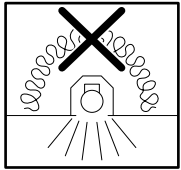

DE Leuchte darf nicht mit Wärmedämmung abgedeckt werden.

GB Luminaire not suitable for covering with thermally insulating material.

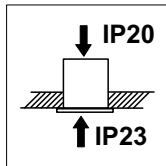
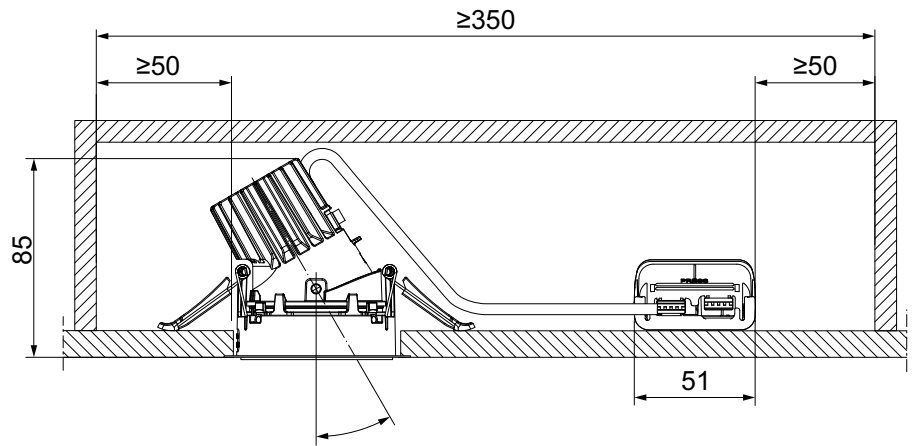
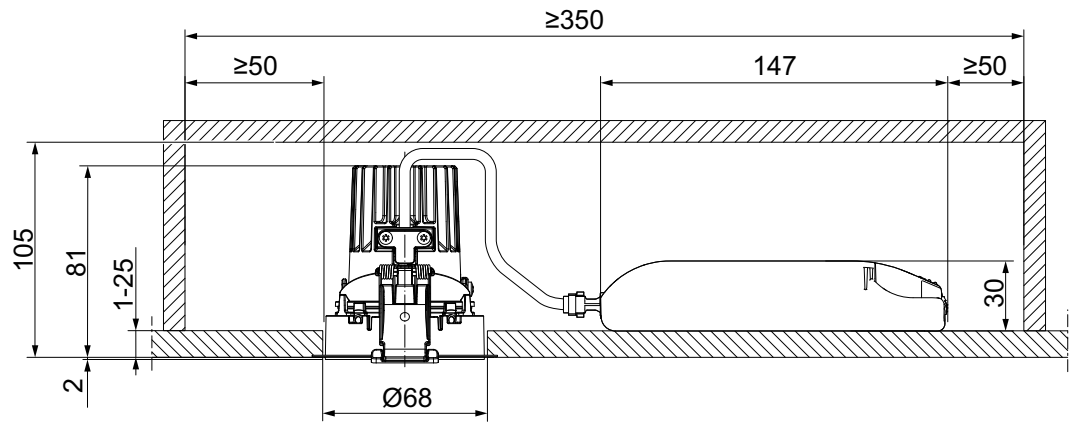

DE Voraussetzung für die Schutzart IP 23 der Leuchte ist die Installation in einer geschlossenen Decke! Die Schutzart IP 23 gilt nur von der Raumseite her.

GB The luminaire is protection type IP 23, only when being installed in an enclosed ceiling! Protection type IP 23 does not apply in the ceiling void itself.

FR L'installation dans un plafond fermé est nécessaire pour qu'une réalisation soit IP 23. La protection IP 23 ne joue que par rapport à la pièce.

IT La premessa per il tipo di protezione IP 23 dei modelli è l'installazione in uno spazio chiuso! Il sistema di protezione IP 23 riguarda solamente gli spazi laterali dai quali fuoreisce il fascio di luce.

NL Voorwaarde voor di classificatie IP 23 van het armatuur is, de installatie in een gesloten plafond. De classificatie IP 23 geldt alleen voor de ruimtezijde

NO/SE Armaturen har kapslingsgrad IP 23 bare når den er bygget inn i tett undertak. IP 23 gjelder bare nedenfra (fra rommet).

FI Kotelointiluokka IP 23 pätee vain umpikattoon asennetulle valaisimelle. Kotelointiluokka IP 23 pätee vain huoneen puolelta.

ES La luminaria equipada cumple con la protección IP 23 cuando se encuentra instalada en un techo cerrado. La protección IP 23 concierne únicamente la zona de la luminaria vista desde el interior del local.



DE Verwendung nur in Verbindung mit PANOS INF Leuchte.

GB Only use with PANOS INF luminaire.

FR Seul en combinaison avec luminaire PANOS INF.

IT Solamente in combinazione con apparecchio PANOS INF.

NL Enkel in combinatie met PANOS INF armatuur.

NO/SE Kun i forbindelse med PANOS INF - belysningsarmatur.

FI Ainoastaan PANOS INF -valaisimen yhteydessä.

ES Solo en combinación con luminaria PANOS INF.

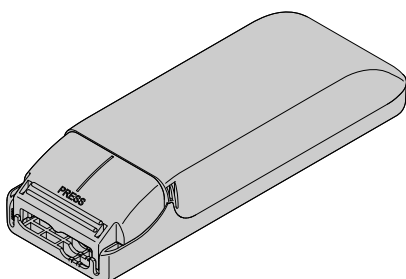

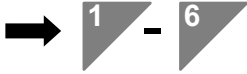

FR **Attention!** Toujours travailler sans tension lors du câblage et de l'installation des luminaires et unités d'alimentation. Le non-respect de cette consigne peut entraîner la destruction des modules à LED.

NO/SE **OBS!** Koble alltid fra strømmen ved kabling og installasjon av lampene og strømforsyningsenhetene. LED-modulene kan ødelegges dersom dette ignoreres.

DE **Achtung!** Während der Verdrahtung und Installation der Leuchten und Versorgungsgeräte immer spannungslos arbeiten. Nichtbeachtung kann zur Zerstörung der LED-Module führen.

IT **Attenzione!** Lavorare sempre in assenza di tensione mentre si cablano e si installano gli apparecchi e le unità di alimentazione. In caso contrario i moduli LED possono andare distrutti!

FI **Huom!** Valaisimien ja syöttölaitteiden kytkemisen ja asentamisen aikana on aina työskenneltävä jännitteettömästi. Muutoin led-moduulit voivat tuhoutua.

GB **Caution!** Make sure that the luminaires and power supply units are always disconnected from the mains supply during wiring and installation work. Otherwise, the LED modules may be destroyed.

NL **Opgelet!** Tijdens het bedraden en installeren van de armaturen en voedingsapparaten altijd zonder spanning werken. Bij niet-naleving hiervan kunnen de LED-modules ernstig worden beschadigd.

ES **Atención** Siempre mantenga desconectada la tensión al realizar las tareas de cableado y de instalación de las luminarias y dispositivos de alimentación. De lo contrario podría destruirse el módulo LED.

i

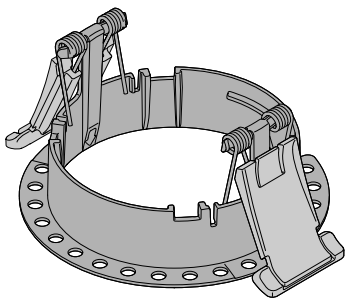

➔ Anleitung / Instruction
06980049

1

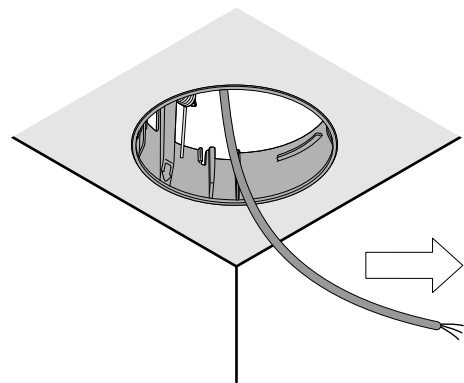

2

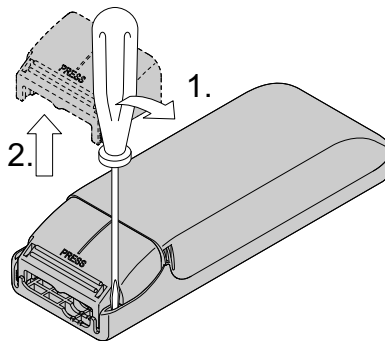

3

~~Durchschleifen - Looping-in (feed through)
Câblage traversant (le luminaire)
Cablaggio passante - Doorlussen
Överkoppling - Koppas - Enlazado~~

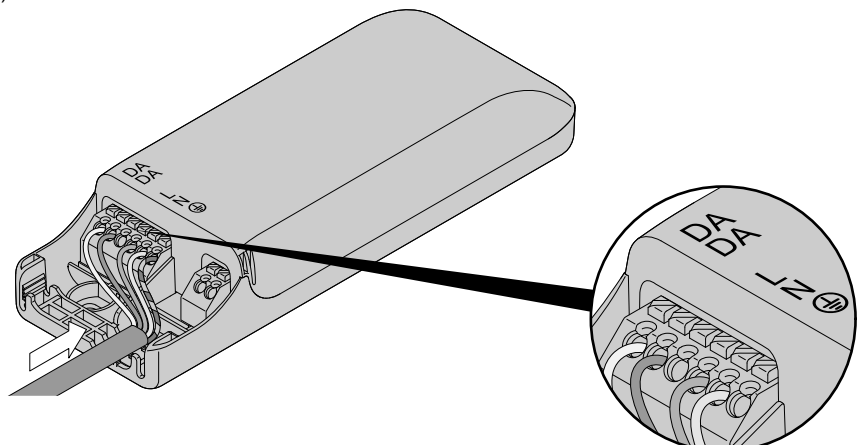
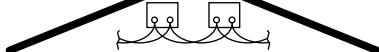

DALI

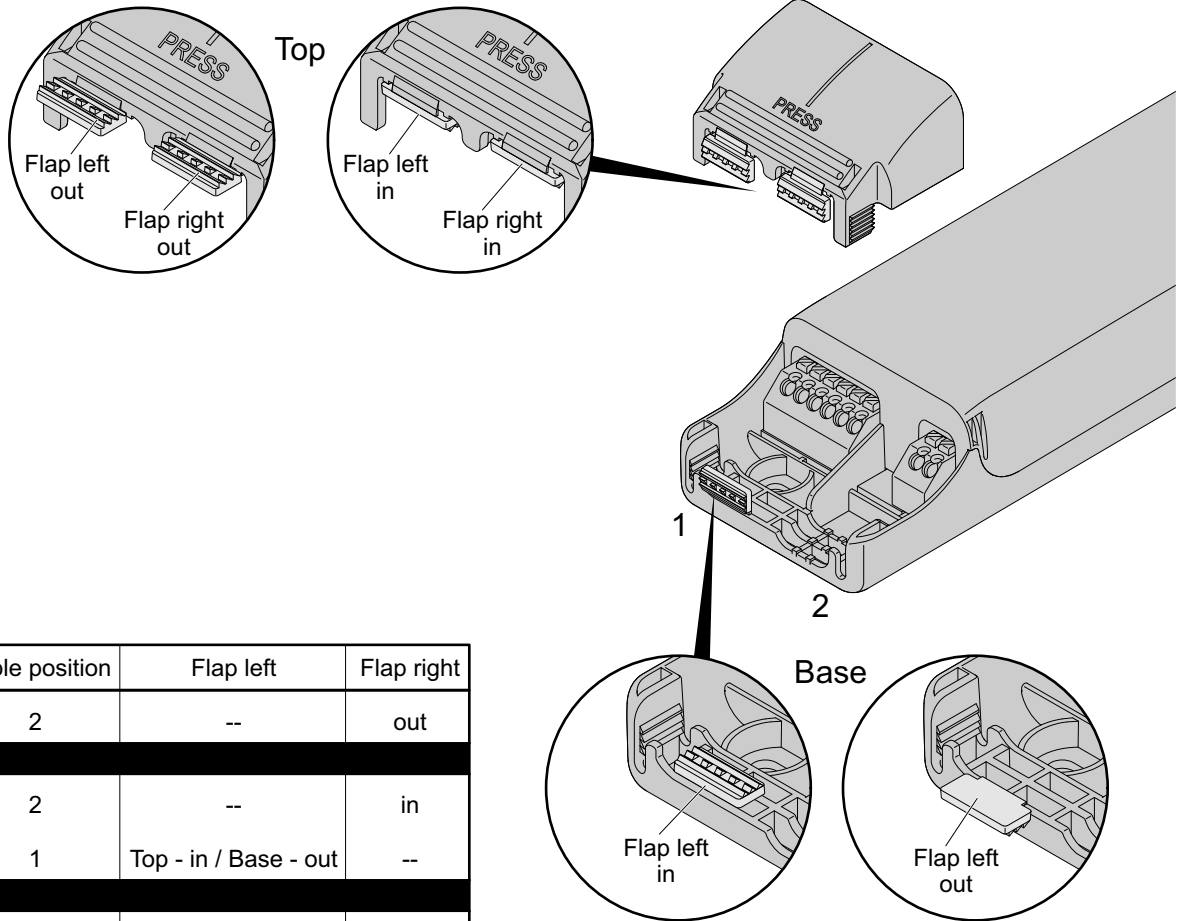

Type	Cable position	Flap left	Flap right
(N)YM-J 5G1,5	2	--	out
(N)YM-J 3G1,5	2	--	in
J-Y(St)Yh 2x2x0,8	1	Top - in / Base - out	--
H05RR-F 3G1,5	2	--	in

switchDIM

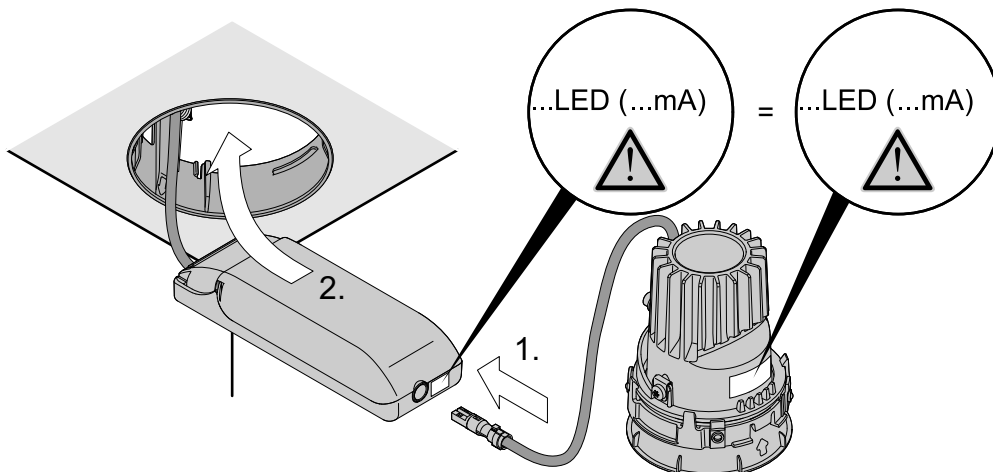
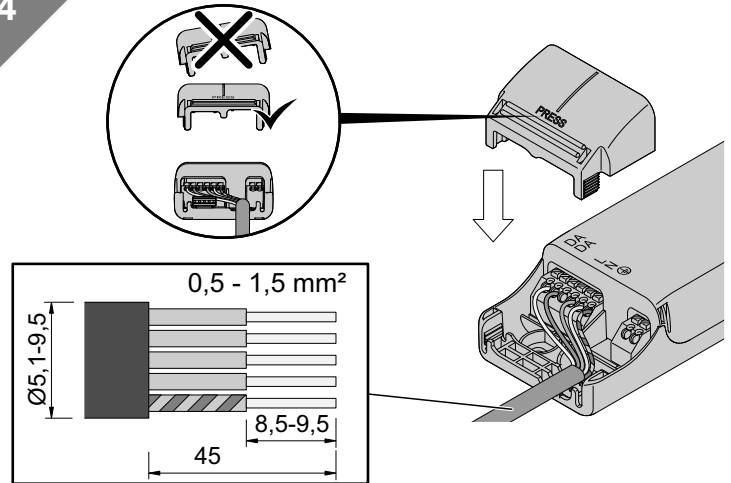
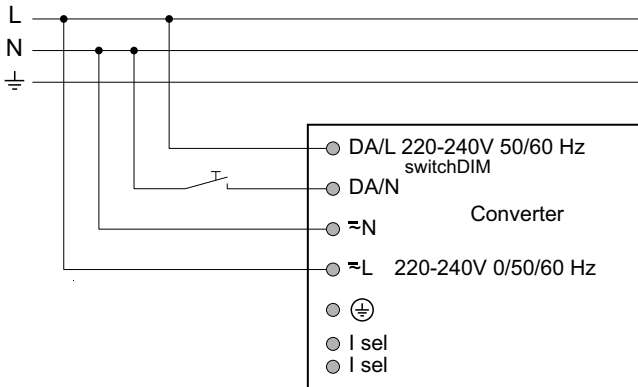

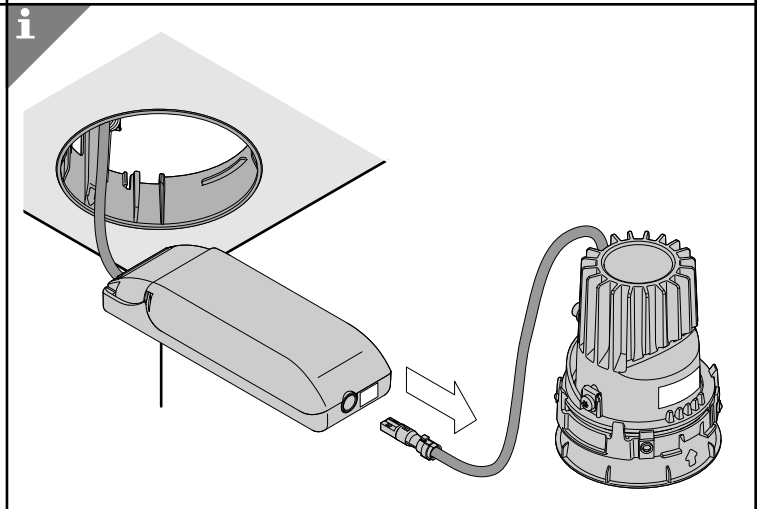
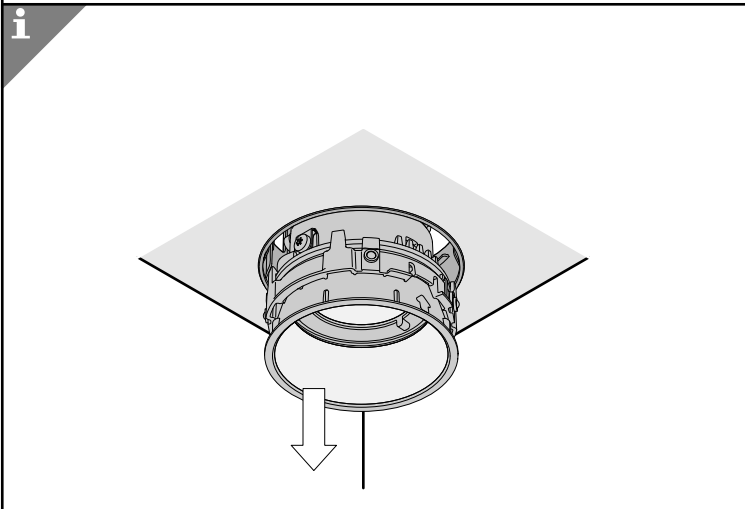
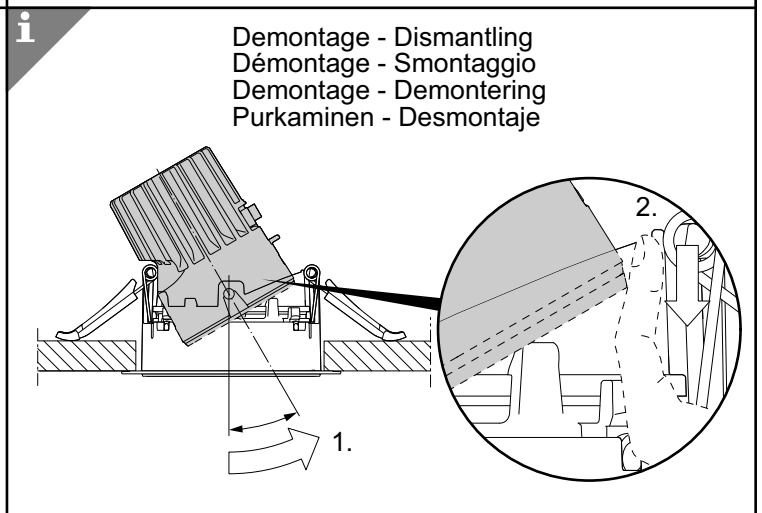
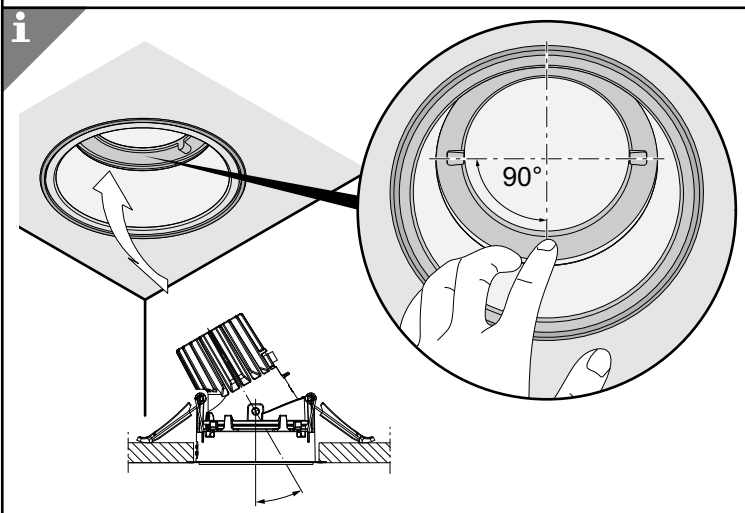
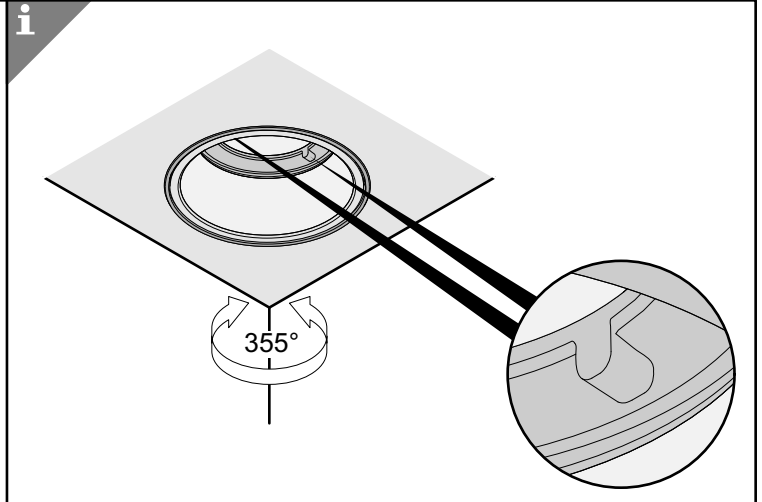
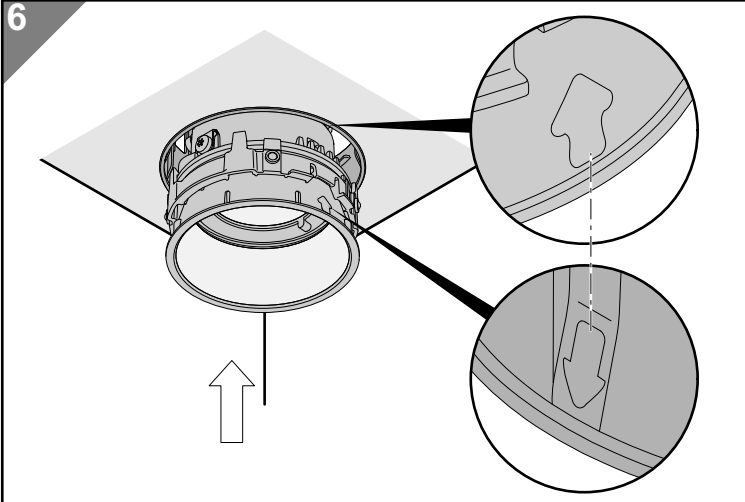

⚠

DE	Reflektorreinigung
GB	Reflector cleaning
FR	Nettoyage du réflecteur
IT	Pulizia di riflettori
NL	Reflektorreininging
NO/SE	Reflektorrengöring
FI	Reflektorin puhdistus
ES	Limpieza del reflector

i

60 800 118

DE	Reflektorreinigungstuch
GB	Reflector cleaning cloth
FR	Chiffon de nettoyage du réflecteur
IT	Straccio per la pulizia di riflettori
NL	Reinigingsdoek voor reflector
NO/SE	Reflektorrengöringsduk
FI	Reflektorinpuhdistusliina
ES	Paño para limpiar el reflector

Technische Änderungen vorbehalten. - Specifications subject to change without notice. - Modifications techniques sans préavis.
 Modifiche tecniche senza preavviso. - Technische wijzigingen voorbehouden.
 Med forbehold om tekniske endringer. - Oikeudet teknisiin muutoksiin pidätetään. - Modificaciones técnicas sin preaviso.